

JETTING

Manual drilling series



TECHNICAL TRAINING
HANDBOOK ON
AFFORDABLE MANUAL
WELL DRILLING

Manual drilling series

JETTING

TECHNICAL TRAINING HANDBOOK ON AFFORDABLE MANUAL WELL DRILLING

Published by the PRACTICA Foundation

Author – Robert Vuik

Co-author – Arjen van der Wal

Peer reading – Richard Cansdale

Structural support – Melanie Stallen

Technical drawings & photos – Don de Koning, Robert Vuik

French translation – Julien Labas

Illustrations – Ron Offerman/Tekenteam

Layout – Marijke Kreikamp/4colour design

June 2010

PRACTICA Foundation develops and disseminates low-cost appropriate technology in water and renewable energy in developing countries. We focus on technology that responds to local cultural contexts, can be locally produced and maintained, and supports existing markets.



PRACTICA foundation
Oosteind 47 - NL-3356 AB Papendrecht - The Netherlands
(t) +31 (0)786150125
info@practicafoundation.nl
www.practicafoundation.nl

Disclaimer

This manual is free of charge. Any parts of this instruction manual, including the illustrations and technical drawings may be copied to meet local needs, without permission from the author or publisher, **provided the parts are distributed free, not for profit and reference to the source is made.** The author would appreciate receiving notice and a copy of any materials in which original text or pictures have been used. For any reproduction with commercial ends, written permission must be obtained in advance from the PRACTICA Foundation.

This instruction manual is available in English and in French and has been developed for use in technical training courses organised for the intended users. In case you want to organize such training, you may contact the PRACTICA Foundation for further information and support.

This publication was made possible by a financial contribution from the United States Agency for International Development (USAID) as part of the West Africa Water Initiative (WAWI).

The United Nations International Children's Fund (UNICEF), PRACTICA Foundation and Enterprise Works/Vita have developed a toolkit for African countries wishing to embark on the professionalization of manual drilling. This toolkit includes Technical Notes, Technical Manuals including this publication, Advocacy Materials, Mapping of suitable areas for manual drilling, Case Studies, and Implementation and Training Manuals. This initiative builds the capacity of the local private sector in order to respond to the ever increasing demand for safe water in rural areas.

The Technical Training Program (TTP) of the ETC Foundation contributed with structural support in the educational aspects of this manual.

While every care has been taken to ensure accuracy of the information given in this manual, neither the publisher (s) nor the author (s) can be held responsible for any damage resulting from the application of the described methods. Any liability in this respect is excluded.

Note to those considering translation or modification; before beginning any translation or modification and in order to avoid duplication of efforts and unintended mistakes, please contact the PRACTICA Foundation. This document or parts of this document may not be copied or published under a new name or author without permission from PRACTICA Foundation.

Foreword

The high cost of developing potable water sources prevents many rural people from gaining access to clean, safe water supplies. Increasing access to improved water supply for under-served people and communities while keeping up with growing populations will require serious consideration of lower cost alternatives to the existing expensive water supply options. The manual drilling sector has proven itself as a successful, lower-cost approach with great potential under suitable conditions. In numerous countries manual drilling techniques are used as an alternative or to complement machine drilling. Drilling 'shallow' water wells by hand using local enterprises, can reduce the cost of a well by a factor 4 - 10 compared to a machine-drilled borehole. This cost reduction not only enables NGOs and Governments to construct more water points, but also 'opens the door' to villagers, farmers, schools and small communities to finance well construction independently through the private sector. Strategies and programs should be adopted to professionalize the manual drilling sector in order to scale-up rural water supply for drinking and irrigation purposes.

Variations of four manual drilling technologies are being used, each with their own advantages, disadvantages and suitability for different geological conditions. This handbook describes the practical aspects of the drilling technique Jetting and is part of a series of 5 handbooks providing the basis for local entrepreneurs to start practicing affordable well drilling.

We suggest that this drilling handbook is used in combination with the manual: **'Understanding Groundwater & Wells in manual drilling'**.

READERSHIP

This handbook can be used as a guide during training sessions for well drillers, local trainers and quality controllers. It also serves as a reference for drilling supervisors, NGOs, development agencies, manual drilling teams and enterprises during the entire drilling process. The handbook consists of three sections that can be read together, or used and printed separately for the various target groups.

NOTE

Technical terms and the way in which subjects are explained are based on the average expected educational level of the intended users. Sometimes, the use of complicated geological and technical terms has been avoided to create better understanding. Please keep in mind that the objective of the handbook is to create better understanding of well drilling in practice, aimed at technical workers of manual drilling teams who may have a limited educational background.

Colophon

AVAILABLE MANUALS IN THIS SERIES:

Technical training handbooks on affordable manual well drilling.

These practical handbooks create awareness of manual drilling for affordable water supply and a roadmap for implementation of manual drilling programs. The manuals provide an extensive and detailed guide for trainers and drilling teams in the use of various drilling techniques for making affordable boreholes. The techniques are explained in simple and understandable language, using clear illustrations and drawings.



1. Manual drilling series: JETTING

This handbook describes in detail the various jetting techniques that can be used to drill wells in loose and soft soil formations. With this technique, wells are drilled in a number of hours rather than days.

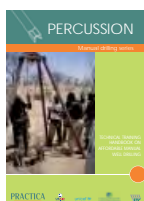

2. Manual drilling series: PERCUSSION

This handbook describes in detail the percussion technique. Although the technique is slower than other drilling techniques, it is the only manual drilling technique that is able to drill through consolidated rock layers.

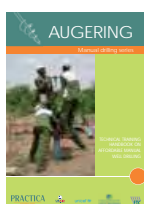

3. Manual drilling series: HAND AUGER

This handbook describes the hand auger technique. This cheap and effective technique is very suitable for sinking shallow wells in soft soils and is excellent for soil surveys. Many drilling teams have this technique in their toolkit to complement other drilling techniques.

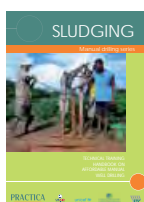

4. Manual drilling series: SLUDGING

This handbook describes the sludging technique, and in greater detail the ROTA-sludge technique. It is a combination of sludging and percussion and is particularly useful due to its versatile application for a range of soil formations.

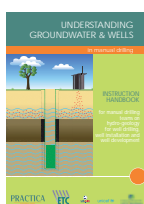

5. Manual: 'Understanding Groundwater and Wells in manual drilling'

The manual 'Understanding Groundwater & Wells in manual drilling' complements the 4 technical training handbooks and highlights those essential subjects which are relevant to manual drilling, geo-hydrology, hygiene, well installation and well development in practice, in simple and understandable language.

Table of contents

Module 1

THE CONTEXT OF MANUAL DRILLING

1. What is manual drilling 2
2. Choices: the 4 manual drilling techniques 3
3. What organizations must know 6
4. Getting started 8

This module creates awareness on manual drilling and provides a road-map for implementation. It is meant for NGO's, governments and implementing organisations and those interested in using manual drilling for affordable water supply.

Module 2

USING THE JETTING TECHNIQUE

1. What is jetting 12
2. What drilling teams must know 15
3. What to bring: tools & materials 17
4. How to drill a borehole 19
5. Specific situations and common pitfalls! 33
6. Rapid well jetting 35

Module 2 describes the drilling technique in detail and includes: how the technique works and where it can be used. This module is a step-by-step explanation that makes use of cartoons to illustrate the drilling process. This module is designed to be used by technical trainers and as a reference for manual drilling teams.

Module 3

MAKING THE DRILLING EQUIPMENT

1. What to buy 42
2. Tips for construction 43
3. Technical drawings 45

Module 3 is meant for local workshops that want to fabricate drilling equipment. It consists of a package of technical drawings, tips for construction and a list of materials that are necessary to make a complete set of drilling equipment.

JETTING

Module 1

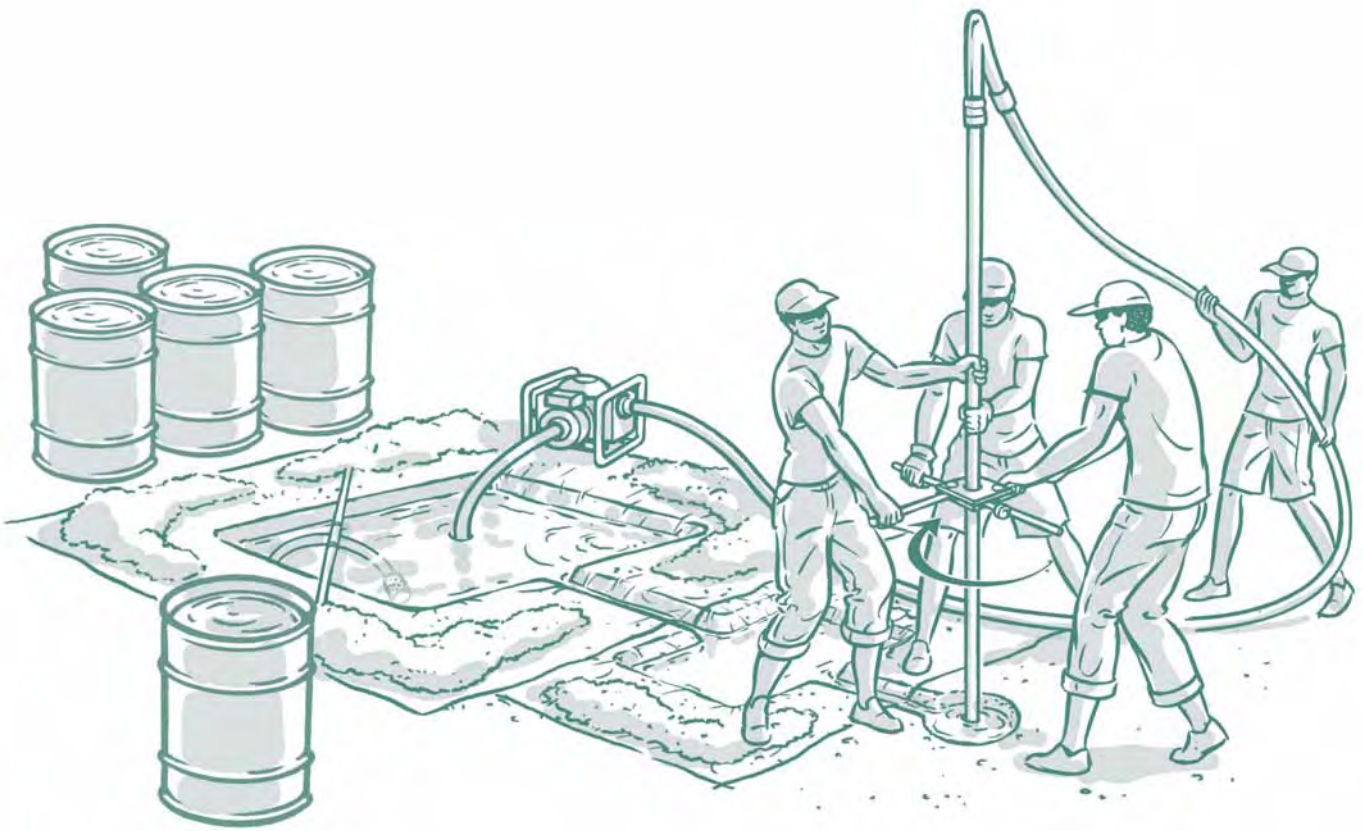

THE CONTEXT OF MANUAL DRILLING

1. WHAT IS MANUAL DRILLING

Affordable water

Manually drilled wells for water supply are more affordable than machine drilled wells and more productive than hand dug wells, thereby providing access to improved sustainable water points at a lower cost. This module describes the context in which manual drilling is used in various countries and elaborates on the techniques and its implementation. It gives insights and creates awareness and is meant for NGO's, governments, implementing organisations and those interested in using manual drilling for affordable water supply. This module might also be interesting for the manual drilling teams themselves, especially once they have gained more field experience in well drilling.

Manual drilling is a practical and affordable solution for wells less than 40 meters deep in alluvial soils (loose material, such as clay and sand) and soft weathered rock formations (such as soft sand stone and lime stone). There are many areas around the world where it can effectively provide water for drinking and for irrigation to un-served rural populations at a fraction of the cost of conventional drilling. This is especially true in small isolated communities that will never benefit from the large donor funded drilling programs because they are often not included in national plans.

WHY MANUAL DRILLING?

- Cost savings: 4-10 times cheaper than a machine drilled well of the same depth.
- Better access to drilling sites with lightweight equipment, remote communities can now be reached.
- Locally manufactured drilling equipment, under € 2,000 initial investment for start-ups.
- Ready-to-go in emergency situations and in politically unstable countries.
- It creates jobs and knowledge remains in the country, even after donor projects are finished.
- Overcomes problems in water quality and quantity in comparison with hand-dug wells.
- Can be used for both drinking water and irrigation.

Machine drilled wells are high in quality, but also very expensive. Hand dug wells are lower in cost and very useful in formations with a low permeability due to their capacity to store water which seeps in through well walls overnight. However, the total yield/day may be low, and water quality may be poor because the water comes from an open source allowing pollutants to enter easily. Hand dug wells also often collapse if not properly lined. A hand dug well lined with concrete rings, preventing it from collapsing, has a high yield, but the price will come close to that of a machine drilled well.

The cost of wells vary among countries and will generally be in the range of € 5000 – 15000 for a 30-meter deep machine drilled well and € 2500 - € 8000 for a lined hand dug well. In many countries manual drilling techniques are used as an alternative.

Costs of 30 meter deep manually drilled wells vary from about € 100 - 2500, depending on geology, country and application (i.e. small scale irrigation to high quality community wells for potable water). The equipment for manual drilling can be locally manufactured, transported and maintained.

2. CHOICES: THE 4 MANUAL DRILLING TECHNIQUES

When a borehole is drilled, different types of geological formations (soil layers) can be encountered. To drill through these diverse formations a range of different manual drilling techniques have been developed and are used around the world. In each case the drilling technique must (a) break or cut the formation, (b) remove the cut material (the soil) from the hole, and (c) if necessary provide support to the walls of the hole, to prevent collapse during drilling.

Each drilling technique has been developed for either one or a range of specific formations (soil layers); therefore it may be possible that combinations of different drilling techniques are used to drill a single borehole. All existing drilling techniques can be divided into four main drilling principles: Hand Auger, Manual Percussion, Sludging and Jetting. Within these four main drilling principles, a wide range of variations have been developed in various countries.

THE HAND AUGER consists of extendable steel rods, rotated by a handle. A number of different steel augers (drill bits) can be attached at the end of the drill rods. The augers are rotated into the ground until they are filled, then lifted out of the borehole to be emptied. Specialized augers can be used for different formations (soil types).

Above the water table, the borehole generally stays open without the need for support. Below the water table a temporary casing may be used to prevent borehole collapsing. Drilling continues inside the temporary casing using a bailer until the desired depth is reached. The permanent well casing is then installed and the temporary casing must be removed. Augers can be used up to a depth of about 15-25 meters, depending on the geology.

Geological application; suitable for unconsolidated formations: Sand, silt & soft clay.



MANUAL PERCUSSION uses a heavy cutting or hammering bit attached to a rope or cable and is lowered in the open bore hole or inside a temporary casing. Usually a tripod is used to support the tools. By moving the rope or cable up and down, the cutting or hammering bit loosens the soil or consolidated rock in the borehole, which is then extracted by using a bailer. Just as with hand augering, a temporary casing of steel or plastic may be used to prevent the hole from collapsing. When the permanent well screen and casing are installed, this temporary casing has to be removed. Manual percussion drilling is generally used up to depths of 25 meters.

Geological application; suitable for unconsolidated and consolidated formations: Sand, silt, stiff clays, sandstone, laterite, gravel layers and small stones

SLUDGING uses water circulation to bring the cuttings up to the surface. The drill pipes are moved up and down. On the down stroke, the impact of the drill bit loosens the soil and on the up stroke, the top of the pipe is closed by hand (or valve), drawing up the water through the pipe and transporting the cuttings to the surface. On the next down stroke, the hand (valve) opens the top of the pipe and the water squirts into a pit, in front of the well. In this pit, the cuttings separate from the water and settle out, while the water overflows from the pit back into the well. The borehole stays open by water pressure. Thickeners (additives) can be added to the water in order to prevent hole collapse and reduce loss of working water (drill fluid). Sludging (with or without rotation) can be used up to depths of about 35 meters.

Geological application; suitable for unconsolidated formations: Sand, silt and clay. If rotated (including a drill bit) it may be possible to penetrate softer-consolidated formations such as stiff clays, soft sandstone, and weathered laterite.



JETTING is based on water circulation and water pressure. As opposed to sludging, water is pumped down the drilling pipes. The large volume of water has an erosive effect at the bottom and the 'slurry' (water and cuttings) are transported up between the drill pipe and the borehole wall. A motor pump is used to achieve an adequate water flow. The drill pipe may simply have an open end, or a drill bit can be added and partial or full rotation of the drill pipe can be used.

Thickeners (additives) can be added to the water in order to prevent hole collapse and reduce loss of working water (drill fluid). Jetting (with rotation) is generally used up to depths of 35-45 meters.

Geological application; suitable for drilling in alluvial material such as weakly cohesive sands, silts and thin layers of soft clay .

CHOICES FOR MANUAL DRILLING TECHNIQUES

Drilling Technique*	Equipment cost (€)	Average drilling speed for 15m in different geological formations (days)**				
		Weak cohesive sand, silt gravel	Soft clay <u>Stiff clay</u> formations	Soft consolidated formations	Soft weathered rock	Un-weathered Crystalline basement rock, e.g. granite
Hand auger	200 - 600	1	1-2 <u>2-4</u>	Not suitable	Not suitable	Not suitable
Percussion	300 -1200	2-3	2-3 <u>3-4</u>	> 3	> 8	Not suitable
Rotary Jetting	800 - 1400	1	1-2 <u>Less effective</u>	Not suitable	Not suitable	Not suitable
Rota Sludging	600 - 1000	1-2	1-2 <u>2-3</u>	> 3	Less effective	Not suitable

Drilling Technique*	Advantages	Disadvantages	Average drilling depth (m)
Hand auger	Easy to use above groundwater table. Cheap equipment	Use of the temporary casing if clay layers are penetrated is very limited If a collapsing sand layer is encountered below a clay layer (through which the temporary casing could not penetrate), the borehole does not stay open	15 - 25
Percussion	Drills hard formations	Slow and high equipment costs	25
Rotary Jetting	Quick	Lots of working water is needed at once	35 - 45
Rota Sludging	Easy to use Applicable in most soft formations	Highly permeable layers (coarse gravel) causes loss of working water and cannot be drilled	35

* Note: Drilling teams are keen on using a variety of drilling techniques to penetrate different geological formations.

**Note: Many different soil layers may be encountered during the construction of one borehole. The information given in the table is an indication of the drilling speed in one particular type of soil.

3. WHAT ORGANIZATIONS MUST KNOW

HOW TO IMPLEMENT MANUAL DRILLING

Using manual drilling as implementing tool for affordable water supply is possible for a wide range of qualities and scales. Before one can start the implementation of a manual drilling program there is a whole list of things to be considered. For example:

- What is the required quality of the wells?
- Who will pay for the construction of the water point?
- Who will be the end user of the well (households, community, farmers, refugees in camps, etc)?
- Are we drilling for potable water, irrigation water or multiple use?
- What is the number of wells that need to be drilled per year?
- Is there already an existing manual drilling sector present and what is their capacity?
- What is the need and scale for quality monitoring?
- What is the size of the project area?
- What is the hydro-geologic potential for manual drilling in the project area (type of soil and the depth of groundwater)?
- What is a sustainable number of drilling teams needed (based on the demand)?
- What is the relation between user density and hydro-geology in the project areas (how many people can we reach with manual drilling)?
- What are the objectives of the implementing organization?
- Etc.

The answers to all these questions (and the objectives for scale and costs) provide the basis for making the right choice of the approach for training and implementation. A few examples:

- For the introduction of shallow irrigation wells the following criteria are very important: The well has to be affordable for the farmer (i.e. low cost materials and shallow), while the water quality is of less importance. A training program in this case will focus on drilling affordable wells, using low cost materials in areas where shallow groundwater exists and where farmers have access to markets to sell their vegetables. Manual drilling enterprises will work directly with farmers.
- For a professional and sustainable water supply to large communities, the government and larger donors are often involved. The most important criteria here are: a very high quality of the well, high quality of drinking water (meeting all standards), sustainability of the well and sustainability of the whole drilling sector. A training program in this case will require a much larger capacity building road map with its focus on professionalization of the drilling sector as a whole, involving technical training, quality control, business skill training, social mobilization and social marketing. Making manual drilling enterprises ready to respond to large tenders and drilling high quality wells, generally through governments or donors.
- Multiple use of wells by households and small communities often requires a mix of both previous options: the well should still be affordable (or partly subsidized), but also have an acceptable water quality.

Always realize that the purpose of the well, the water quality, affordability and sustainability go hand-in-hand and that all are important for a right choice of the further approach in training and implementation.

GOING TO SCALE

Once a feasibility study has revealed that there is a high potential for manual drilling in a given area or country

Figure 1. Range of implementation possibilities

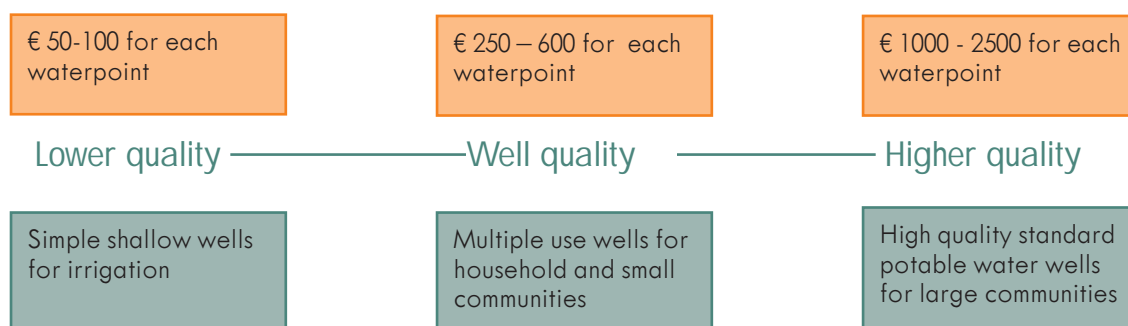

and the first team(s) have been drilling successfully, there is potential to scale up the capacity of the sector.

Scaling up is often explained as: training more teams. That is partly what it is, but be careful: training more teams alone is not enough to ensure the quality, affordability and sustainability of wells! When going to scale, not only the drilling enterprises are involved. Other actors play an important role in this process. To visualise this, let's go back to the three examples of the previous page:

a) shallow wells for irrigation, b) high quality communal wells and c) multiple use wells for households.

In all these three examples not only the purpose, quality and price of the wells are different, but also the actors involved. Example b for instance, has its focus on professionalization of the drilling sector as a whole. This involves of course the drilling enterprises, but also quality controllers, the government (responsible for a national quality control system and certification), social actors (to guide communities) and pump suppliers. While in example a, the drilling enterprises, farmer associations and pump suppliers play the biggest role.

Whenever starting a program to go to scale it is important to realize that such a program is not 'a borehole drilling program' only. Going to scale requires a capacity building process with its focus on training, repetition, quality and sustainability of the manual drilling sector. This may take as much as 3-5 years to develop. For an example of a more detailed roadmap on the implementation of larger manual drilling programs please read the manual; **'Professionalizing the Manual Drilling Sector in Africa'** A capacity building program to increase access to safe water in rural areas.

THE FIRST STEPS IN ANY MANUAL DRILLING PROGRAM

Feasibility study

A feasibility study will assess the potential for manual drilling and whether it is a practical solution for water supply under the given conditions. Collecting information on hydrology (depth, quality and quantity of groundwater), geology (soil type) and population density will provide a clear indication of areas with the highest potential. It is also of great importance to assess the existing drilling sector. Do manual drilling enterprises already exist? And if so, what is quality of their current work? And what training

is required? What are the roles of the other actors involved in the sector such as NGO's, workshops, well diggers, Governments, pump suppliers, etc? This information will be used to determine the right approach for training and implementation, building on- and reinforcing the existing local capacity.

Technical hands-on training on manual drilling

If there is not an existing manual drilling sector present or if there is a need for further improvement of technical skills, a technical hands-on training on a specific manual drilling method(s) is required.

The technical trainer will advise on the purchase of tools and well construction materials and assure that the drilling equipment is fabricated properly. During several weeks a hands-on technical drilling training is given to a team(s) of selected manual drilling trainees. During and after this first training several wells are drilled, allowing the teams to practice and improve their technical skills.

Follow-up and geo-hydrological training

Once teams have gained sufficient experience in the use of the equipment while drilling boreholes, they are ready for the next step: a technical follow-up training combined with a training on geo-hydrology, hygiene, well installation and well development.

Although most existing manual drilling enterprises are very capable of drilling a borehole, a lot of improvements can be made during the construction and development of the wells, resulting in a better water quality, quantity and hygienic use of the well. Most manual drilling teams experience problems with site selection, loss of working water, soil texture determination, logging, well casing installation, well development, water quality and well yield (flow rate of the well). These problems may occur when the drilling process is not completely understood and important steps are missed. The classroom training on geo-hydrology **'Understanding Groundwater & Wells in manual drilling'**, addresses the above issues. During this training, the drilling team will get a technical follow up training in the field to bring the theory and lessons learnt into practice.

Depending on the size and objectives of a program, additional training can be given on business skills and quality control for manual drilling teams.

4. GETTING STARTED

The construction of a well, using manual drilling techniques is a complicated process. Before drilling starts a good drilling site has to be selected, where experience suggests that there will be an adequate quantity of good quality groundwater. During the drilling process there are a lot of different aspects which require attention to prevent things from going wrong. Besides the practical drilling skills which are executed at ground level, attention also has to be paid to important processes which are happening below ground level during drilling. Water used in drilling (working water) could flow away or worse; the borehole could collapse, burying part of the drilling equipment. And finally, once the hole has been drilled, the well casing, screen and sanitary seals have to be installed at the right depth, preventing contaminated water from entering, and ensuring a sufficient yield. With this in mind, it becomes clear that the introduction of manual drilling needs adequate supervision, with proper training and guidance of the drilling teams.

PREPARATIONS AND THE FIRST TRAINING

Making the drilling equipment

The decision to use quality tools is one of the key factors for success that manual drilling teams can make. Although this looks obvious, the quality of the tools is often overlooked, resulting in loss of equipment and breakdowns in the field. How to avoid this?

All tools and equipment are purchased and made locally. It is important that a good workshop is selected to manufacture the drilling equipment. The workshop should have the right equipment and be skilled to do the job! Module 3 of this handbook has all the technical drawings of the equipment and will guide the workshop during construction. Although it may be expected that the workshop is able to make quality drilling equipment from the drawings, when it is the first time for them, additional supervision is useful. Guidance during construction and quality control of the equipment before it leaves the workshop is essential. At first this quality control can be done by a technical trainer. In a later stage, the drilling enterprises will take care of the quality control themselves.

Training the drilling team

Manual drilling must be understood as a profession that develops through training, hands-on experiences, successes and failures. Technical training sessions by experienced

drillers/trainers are an essential base for new teams to become professional manual drillers.

Make a selection of trainees before training starts: It is important that the trainees either have experience or affinity with wells (pump workshops, well diggers) and are motivated to run their own business. On average, a team consists of 5 or more workers and 1 team leader. During several weeks, hands-on technical drilling training is given to the manual drilling trainees. During and after this first training, several wells are drilled. It is good to provide the training and these first wells in an area that consists of loose soils, which are easy to drill. This will allow the team(s) to practise and improve their technical skills, without becoming frustrated.

Important: during this first practice period (a few months) the team(s) will come across problems, may have questions, experience difficult situations or worse may lose some of their equipment. Realize that this is all normal and part of the learning process! It is important that the team(s) are guided well and have access to experienced trainers. After a few months of practise a follow up training will evaluate the problems encountered with the drilling team(s).

GUIDING THE NEW TRAINED TEAM

Drilling in a new area

When a drilling team is new to an area, it is important for them to have information on the geology (soil type) they are going to drill. And how deep they have to drill. In other words: what is the depth of the groundwater and how deep do they need to drill into the groundwater to find a good yielding aquifer?

There are several ways to get this information: Ask villagers to show existing hand dug wells and try to talk with well diggers. They can give information on the different types of formations (soil) and the level of the ground water in dry- and in rainy season. To complement this information; the team should drill its first well to the maximum possible depth. During this exploration, soil sampling will help them to define the depth of a good aquifer. Note that drilling in valley bottoms, floodplains and riverbeds is likely to be more successful than high up in the hills.

Remember; there is NOT a standard for the depth of drilling. This always depends on the depths of an aquifer and the requirements of the users and the pump.

Selecting construction materials

For the well casing different types of PVC pipe are used. The quality can vary from cheap drain pipes with self made filter screens to expensive, high quality factory slotted filter screens and casing pipes. Around the filter screen a **gravel pack or filter** cloth is placed to reduce the inflow of fine sand. A sanitary seal is placed to prevent pollution from entering the well. Find more information on construction materials in module 2, chapter 2: What the drilling teams must know.

Finalizing the well

Once installed the well should be further developed to maximize the yield of the well. Then an apron and a pump are placed.

For more details see the manual: '**Understanding Groundwater and Wells in manual drilling**'. An instruction manual on hydro-geology, hygiene, well installation and well development.

Giving a follow up training

When the team has drilled a number of wells and gained practical experience, they are ready for a follow-up training 'Understanding Groundwater and Wells in Manual Drilling'. This training helps them to understand the drilling process and the theory behind it. It will allow the drilling teams to solve problems in the field. During this training, the teams will get a technical training in the field to bring the theory and lessons learnt into practice.



JETTING

Module 2



USING THE JETTING TECHNIQUE

1. WHAT IS JETTING

This second module of the jetting handbook teaches entrepreneurs and technical trainers how to use the drilling equipment and how to drill wells for drinking water, using the manual rotary jetting technique. It also explains another type of jetting; the so called rapid well jetting, which is recommended for low cost shallow wells for drinking and/or irrigation water.

HISTORY

A desk study reveals that at present there is very little practical open source information available on jetting techniques. Existing information consists of specific case studies and basic descriptions of the technique, while open source information on the use of drilling equipment and fabrication of tools is absent. This practical module is created with information compiled from available literature, field observations in various African and Western countries, discussions with local drilling teams and interviews with jetting experts. This module summarises best practices in drilling with the jetting technique.



The name **manual rotary jetting** comes from 'the removal of material from the borehole by the washing action of a water jet'. Therefore the technique is called jetting. It is also referred to as 'wash boring'. A rotating handle is attached to the drilling pipes to break and cut the soil formations; therefore others call it 'rotary jetting' or 'hand turning'.

Where is jetting coming from?

Manual rotary jetting was developed overtime through a combination of the manual rapid well jetting technique and conventional rotary machine drilling. Richard Cansdale, a key pioneer in rapid well jetting, first perfected this technique on coastal sandy beaches in order to extract clean salt water for aquariums and marine laboratories. He then introduced the technique in Nigeria and other countries to access groundwater in riverbeds and floodplains. It is also used for drilling inside hand dug wells to increase the yield. Rapid well jetting is the simplest and cheapest form of jetting and is suitable for areas with shallow water tables in very soft and loose sandy soil conditions, while rotary jetting has been developed to drill deeper. Nowadays jetting is being used in Nigeria, Niger, Madagascar, Chad, Senegal, Burkina Faso, Uganda, Kenya, Sudan, Benin, Sri Lanka and Western countries.

HOW DOES IT WORK?

A jetted well is a small diameter borehole that is drilled into the ground using a large volume of water that is pumped through the drilling pipe. The water jet washes down the drilling pipe in loose and soft soil formations such as sand, silt and fine gravel. Jetting is most suited for shallow water tables, but with rotary jetting deeper wells can be drilled. A PVC casing and filter screen are placed inside the drilled borehole and the remaining space between filter screen and borehole wall can be filled with a gravel pack to prevent fine sand from entering the well.

A motor pump is used to circulate a large volume of water through the drilling pipe to the bottom of the borehole. At the same time human power is used for the rotating and percussive movement of the drilling pipe. How deep you are able to drill depends entirely on the type of soil you encounter and the amount of water that is available on-site, but generally wells can be drilled up to 35 meters, and exceptionally to 50 meters.

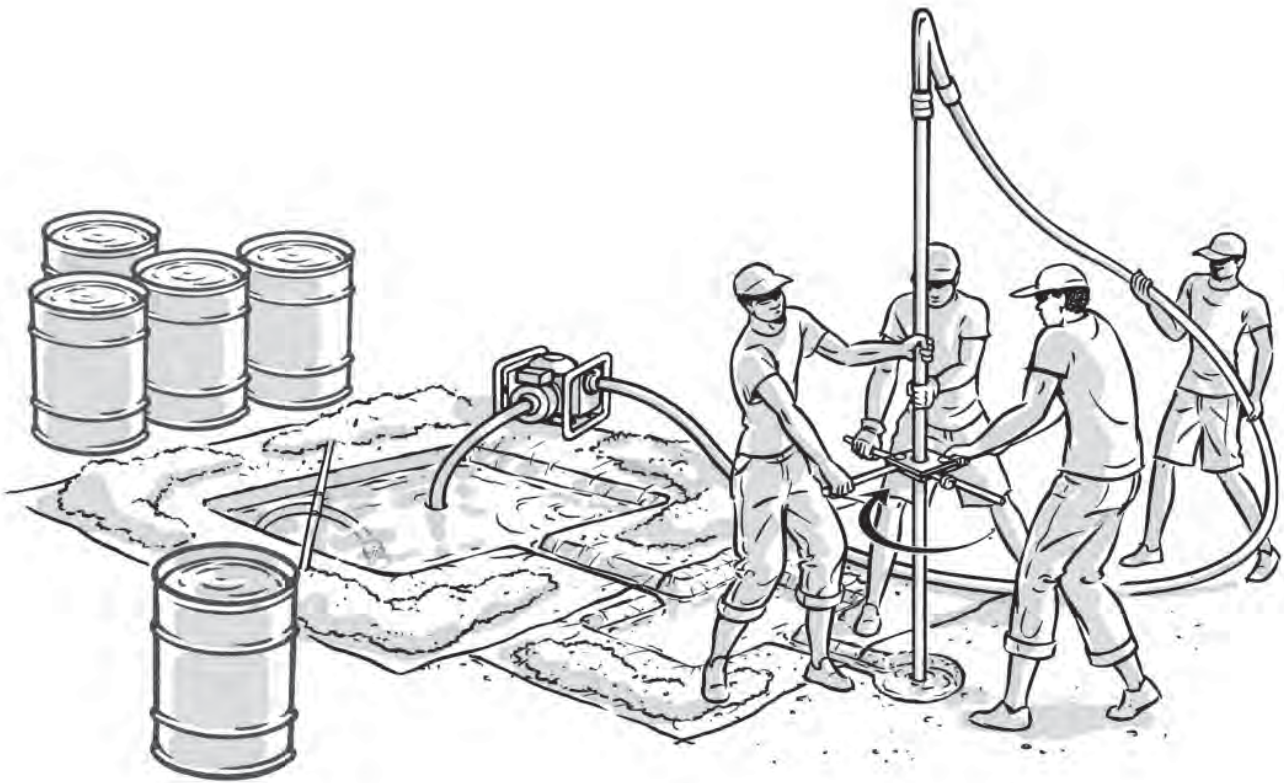

The borehole is kept full of water to prevent the well from collapsing, while the drill bit cuts into the formation. The 'slurry' (water and cuttings) are transported up the borehole between the drill stem and the borehole wall. A mud pit, dug close to the borehole, allows the cuttings to settle and the 'clean water' to circulate back into the drilling pipe.

During jetting it is important to conserve the water supply, especially in highly permeable sands and gravels, where as much as 5 drums of water/ hour may be needed. Thickeners (additives) can be mixed with the water to plaster the borehole wall in unstable formations, which prevents the working water from flowing away and increases viscosity of the water to bring up the cuttings more easily.

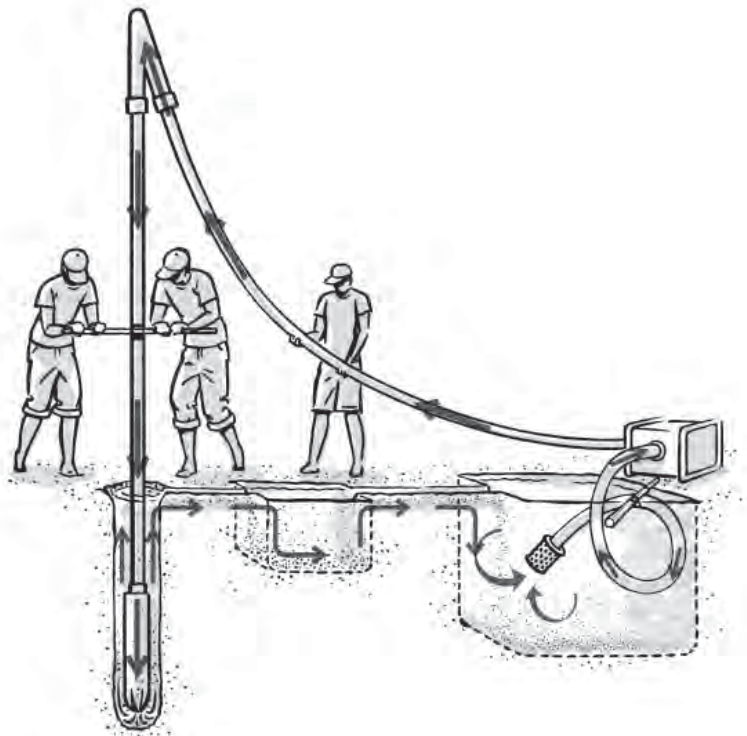

THE 2 JETTING TECHNIQUES

Rapid well jetting is also called 'clear water jetting' or 'farmer jetting' and consists of driving a plastic pipe down with a large volume of water from a motor pump.

The technique can be used up to 6-10 meter drilling depth in loose sandy formations. The chapter 'Rapid well jetting' later in this module describes this technique in detail. The technique is very useful for deepening collapsing hand dug wells. It is also used to drill low cost shallow wells for drinking water and irrigation.



With **manual rotary jetting** boreholes can be drilled much deeper than with rapid well jetting. It is generally being used for drinking water wells.

A drilling bit and rotation arm are attached to metal drilling pipes allowing the penetration of clay, gravel and sand with loose to medium compaction. Because additives are used to thicken the water and make a 'mud', as the water is circulated, the wall of the borehole becomes plastered. This reduces the loss of water and collapsing of the borehole. In practice, it increases the time available for the drilling and the well installation process.



ADVANTAGES & DISADVANTAGES

Advantages of jetting.

In loose formations such as sand and fine gravel the drilling pipe sinks down easily, making it the quickest manual drilling technique. Wells can be drilled in a number of hours rather than days needed with other techniques.

The equipment is light, making it easy to transport, especially in rural areas.

Disadvantages of jetting.

The amount of water available on site can be a limitation. Some wells can be drilled with just a few barrels of water (500 – 1000 liters), whilst others need as much water as a large water truck can hold.

Drilling is done in loose soil structures, which can easily collapse. To prevent collapsing, the borehole needs to be kept full of water during the entire drilling and well installation process.

Clay can be penetrated only very slowly. Very coarse gravel (pebbles) and other highly permeable materials (cracks in the formation) may create too much loss of water so that they cannot be drilled. If deeper wells are drilled in permeable soils (sand and gravel), expensive drilling additives are needed, which increase the total cost of the borehole.

2. WHAT DRILLING TEAMS MUST KNOW

BEFORE YOU START DRILLING

Before you start drilling, there are some important things you need to know. First; a good drilling site needs to be selected, where a good quantity (high yield) and quality (no pollution) of groundwater is expected. Second; some knowledge of construction materials such as PVC casings and also of soil sampling and drilling safety could help you to become a better driller.

Selection of the drilling site

Selecting a good location for the well is not always easy and depends on: needs and preferences of the users, expected groundwater level, type of formation (soil) and any nearby sources of pollution (latrines) that may be harmful.

Some tips to help you in site selection:

- o The needs, preference and ideas of the users should be placed first when you select a location.
- o Always discuss advantages and disadvantages of the selected location with the users (you are a specialist who has knowledge about the expected quantity and quality of water in relation to the selected site).
- o Ask villagers to show existing hand dug wells and try to talk with hand diggers. They can give useful information on the different types of formation (soil) and the level of the ground water in dry- and in rainy season.
- o Note that drilling in valley bottoms and riverbeds is likely to be more successful than high up in the hills. Keep in mind that the selected site is not flooded during the rainy season (if it is the lowest point in the landscape).
- o Always choose a site at least 30 m away from a latrine. Avoid other possible sources of pollution such as waste dumps, fire places and fuel stations.

MATERIALS

What about the PVC pipes?

For the well casing, you can use different types of PVC. The quality can vary from cheap drain pipes with self made filter screens to expensive, high quality factory slotted filter screens and casing pipes. The choice of pipes depends on: diameter of the pump (the pumps should fit the pipe), type of the well (irrigation or potable water), user intensity (household or communal) and the users budget (low or high).

Buying the pipes

You can buy high quality factory slotted pipe in a specialized hardware store. The pipe has a thick wall, is strong and has a lot of slots per meter filter screen, resulting in a high water inflow. The pipes are expensive and are often used for large communal wells.

You can also buy cheaper PVC pipes. You can find these regular pipes in almost each hardware store.

The wall thickness should be 3 mm or more to prevent the pipes from breaking. In this case you have to make the slots of the filter screen yourself.

Making the slots in the filter screen

Use a hacksaw to make slots in the pipe. For a 4-inch screen, 6 parallel lines are drawn along the full length of the pipe. The spaces between the alternate lines should be about 4-5 and 6-7 cm (see drawing). The slots are sawn between 6-7 cm lines. The distance between the slots should be about one centimeter.

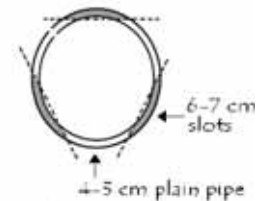

Guideline: the length of the filter screen should be at least 3 meter. The last meter of pipe has no slots. This is called the sump in which fine particles that enter the well screen can settle, without blocking the filter screen. The bottom is closed with a PVC cap or by cutting and bending the bottom of the PVC pipe.

Gravel pack

Coarse river sand in the range 1.5-3 mm is used as a gravel pack. The gravel pack fills the space between the borehole wall and the filter screen. It may also serve to filter some of the fine sand particles from entering the well. Use a minimum and a maximum sized sieve to prepare the 'gravel'.

Sanitary seal

During installation a sanitary seal is placed on top of the gravel pack to prevent pollution entering the well. A sanitary seal is made of clay or cement grout. If cement is used for the seal, first a half meter of clay is backfilled on top of the gravel pack to prevent the cement from penetrating the gravel pack.

Drilling fluid

Although expensive, for rotary jetting polymers (additives) are used. They thicken the working water and plaster the borehole wall. Natural polymers are biodegradable; in other words, after some time they disappear naturally. There are different additives available which are known by different names in several countries, each with their advantages and disadvantages. Please see the manual 'Understanding Groundwater and Wells in manual drilling' for more details.

TO REMEMBER DURING DRILLING

Take soil samples

Soil sampling helps you to understand what material you have been drilling through and helps you to indicate when you have reached the final depth of drilling



This sampling is also a good way to determine how easily water flows through the pores (open space) of the drilled material. Sand and gravel are very permeable, and are therefore suitable layers which transmit the water easily.

If the drilled material is very fine, such as silt and clay, it will not transmit water easily and is called impermeable. Do not install the filter screen in this formation.

Field tricks

Take a sample of the soil and squeeze it into a ball, between your hands. Then drop the ball from a height of one meter above ground level.

- o If the ball consists of non cohesive (non-sticky) particles, the ball totally falls apart. In this case the material is permeable. The particles of sand or gravel will be easily visible.
- o If the ball falls apart only partially, the soil contains some silt or clay and sand. The formation has a low permeability.
- o If the ball only deforms and remains more or less in shape, it is composed of clay, and is described as impermeable.

Drilling safety

Keep the borehole full of water at all times!

A frequently made mistake is to go for lunch, without keeping an eye on your working water. When you come back, the water level in the borehole has dropped, the hole has collapsed and your **equipment is lost!**

When you have to leave the site overnight during drilling, you need to take important precautions:

- o Lift up the pipe a few meters in the borehole or take it out. This will prevent the drilling pipe from getting stuck.
- o Always keep your borehole full of water, also during the night. This is necessary to prevent the borehole from collapsing.
- o Protect the borehole and the mud pits. Take measures to prevent cattle from stepping in

Please be aware that drilling can be a dangerous activity. Watch each other and ask villagers (especially children) to watch you from a safe distance. This prevents them from accidentally being hit by one of the drilling pipes.

NOTE

These are a few guidelines to help you during drilling. You can find more information on soil, groundwater, hygiene, sampling, well installation and well development in the manual 'Understanding Groundwater and Wells in manual drilling'.

3. WHAT TO BRING

Tools & materials



Jetting drilling pipes (30 meters)



Jetting clamp (1 piece)



Jetting drill bit
(1 or 2 pieces)



Jetting swivel (1 piece)



Motor pump set (1) 3,5-4,5 Hp
engine, 2" pump outlet
(able to pump 15-20 m3/h)



Filter for pump set
(1 piece)



Flexible suction hose
(2 meters)



2" flexible delivery hose
(5 meters)



Hacksaw (2 pieces)



Pipe wrench (3 pieces)



Shovel (2 pieces)



Toolbox (full)



Tarp (plastic sheet) 4x6 meters (1 piece)



Bucket 12 liters (2 pieces)



Empty oil drums (200 liters) (5 pieces)



Sieves 1,5 & 3 mm (2 types)



Additives (1 bag)



Inner tube (2 meters)



PVC casing pipe



Oil + gasoline (1 + 5 liters)



Sieved gravel pack (50 kg bag)



Depth measuring tool (1 piece)

4. HOW TO DRILL A BOREHOLE WITH ROTARY JETTING

STEP 1 PREPARING THE MUDPIT

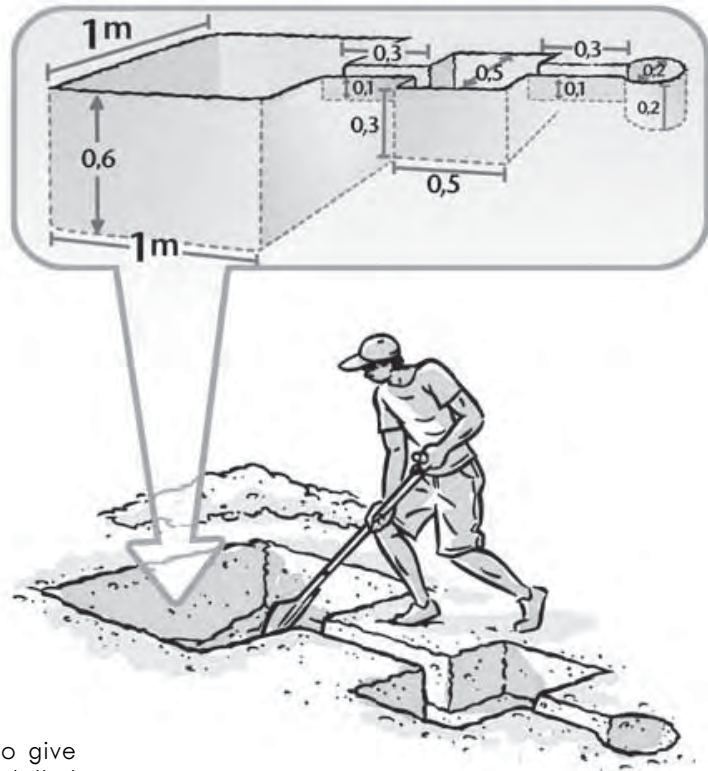

Dig the mud pits

Start with digging the mud pits. These are dug to give storage for your drilling water. In the pits, the drilled material is separated from the drilling water.

The little pit first separates larger material and the big pit separates smaller material.



Cover the mud pits

In sand it is helpful to line the mud pits with a plastic sheet to conserve your water. An alternative is to seal the mud pit with clay or drilling fluid (water + additives)

STEP 2 PREPARING THE EQUIPMENT



Connect the drill bit and the swivel

Connect the drill bit and the swivel to the drilling pipe using the pipe wrenches.

Tip

Look after your drilling pipes! Keep threads clean and apply some grease to the threads. Especially during transport protect threads with a PVC cap, socket or wrapping, to prevent damage.

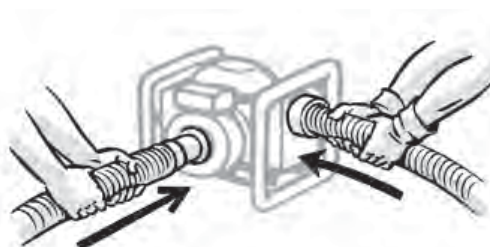

Place the pump set

The pump set is placed next to the larger mud pit. The delivery and suction hose are now connected to the pump set.

Tip

An airtight seal between the SUCTION hose and the pump is important! If the joint sucks in air, wrap inner tube tightly around the connection. If the seal is leaking, the pump will suck-in air and will not work well. Clay may also be used to seal leaks.

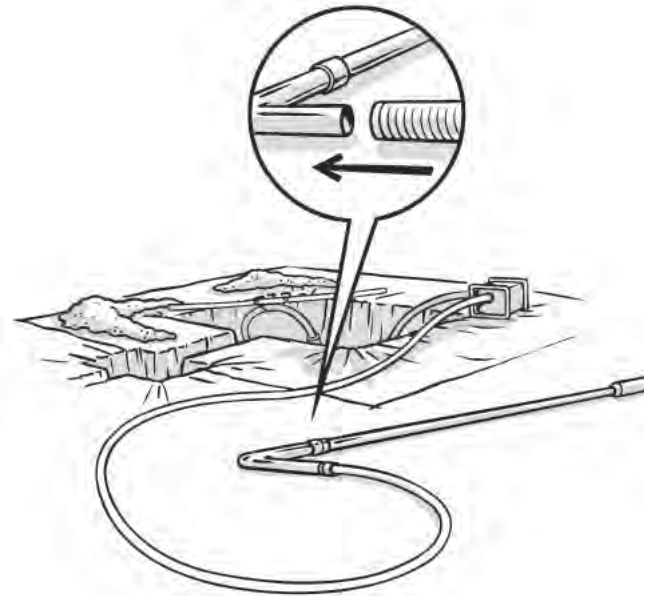
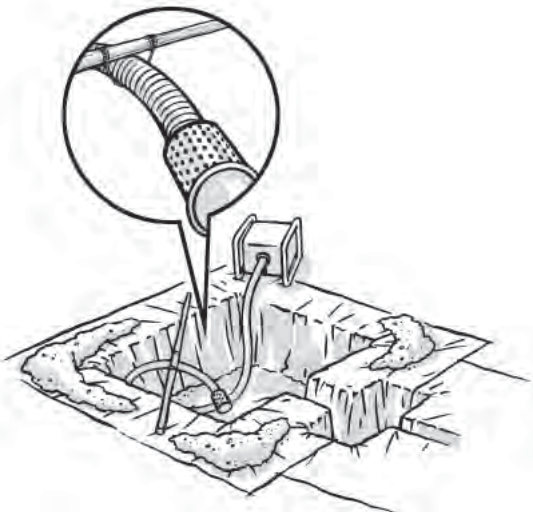

Attach the two flexible hoses

The short suction hose (2m) has a filter at the end. Place the filter in the large mud pit and attach it to a pole to hang it about 30 centimeters above the bottom of the pit! Connect the long delivery hose (5m) to the swivel.

STEP 3 PREPARING THE DRILLING FLUID

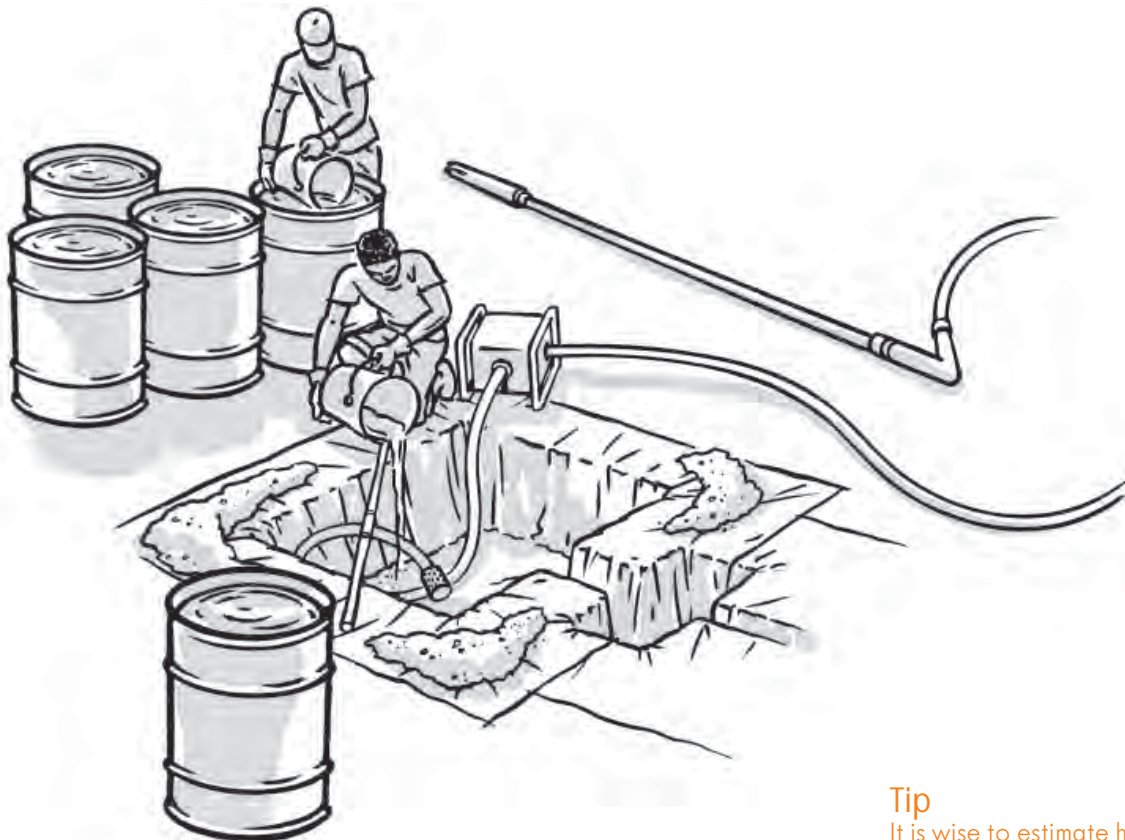

What about the water supply?

Fill the mud pits with water from a nearby well or river (ask local people to assist you or bring it in by truck).

Make sure you have water all day! You will lose water during drilling.

Tip

It is wise to estimate how much water you will need for a day's drilling. Make sure you have more than enough.



Make drilling fluid

Add a few hands of additives to the water until the water is getting thicker.

Drilling fluid helps to bring the drilled material up to the surface and reduces loss of water and the chance of collapsing.

Tip

When you are losing a lot of working water or the drilled material is not coming up, more additive can be mixed.

STEP 4 ALMOST READY TO START!



Set up the drilling pipe

Place the drilling pipe with the attached swivel and drill bit inside the starter hole.

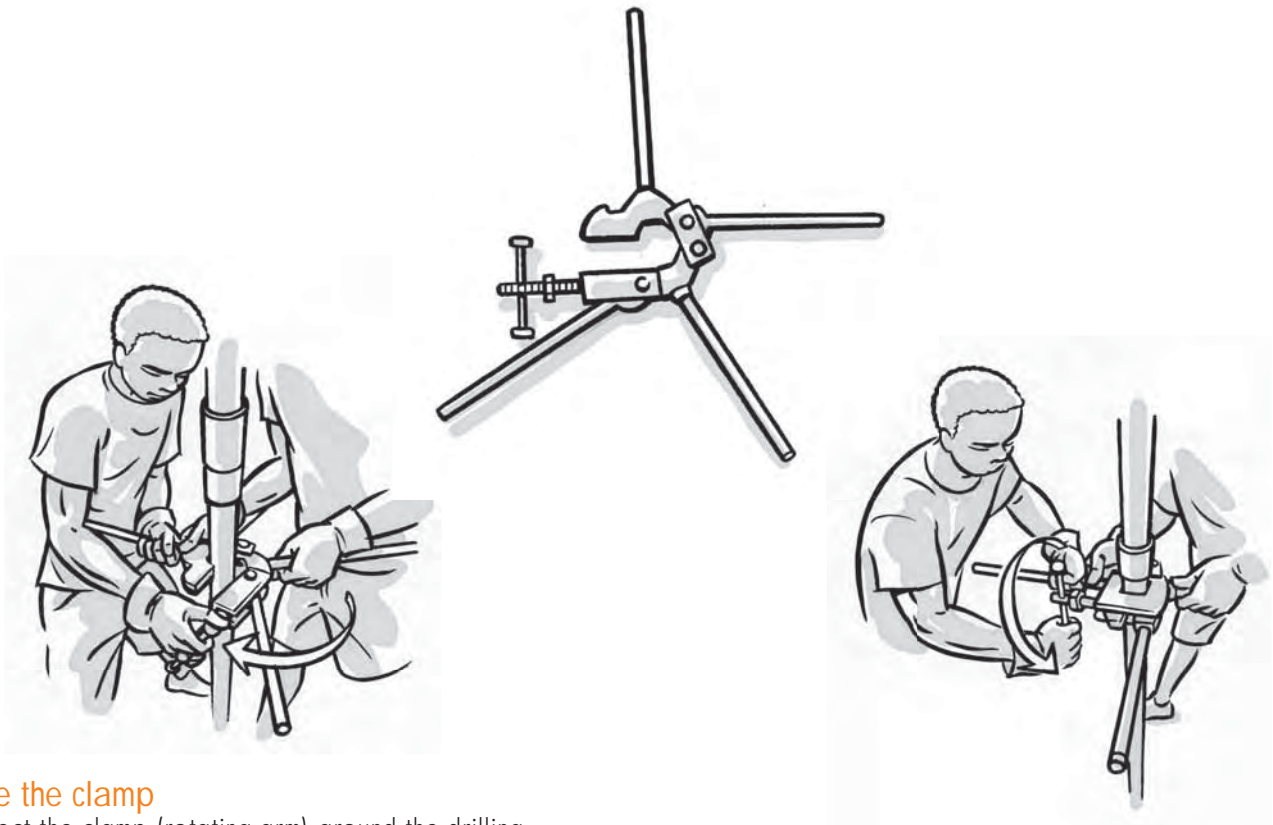

Place the clamp

Connect the clamp (rotating arm) around the drilling pipe. Connect the clamp at a comfortable working position; the average chest height should be the aim.

STEP 5 STARTING TO DRILL

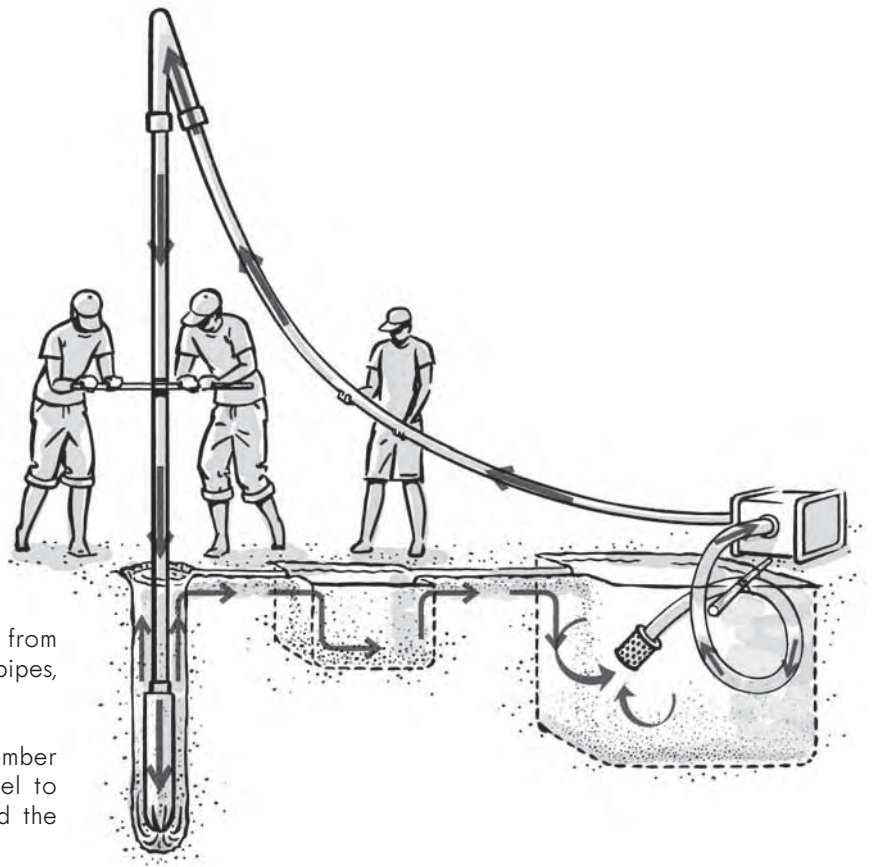

Water circulation

Switch the engine on to start pumping water from the mud pit through the hoses into the drilling pipes, creating a constant water circulation.

2-4 team members will hold the clamp. 1 team member keeps the delivery hose straight with the swivel to prevent the hose from getting wrapped around the drilling pipe when the clamp is turned.

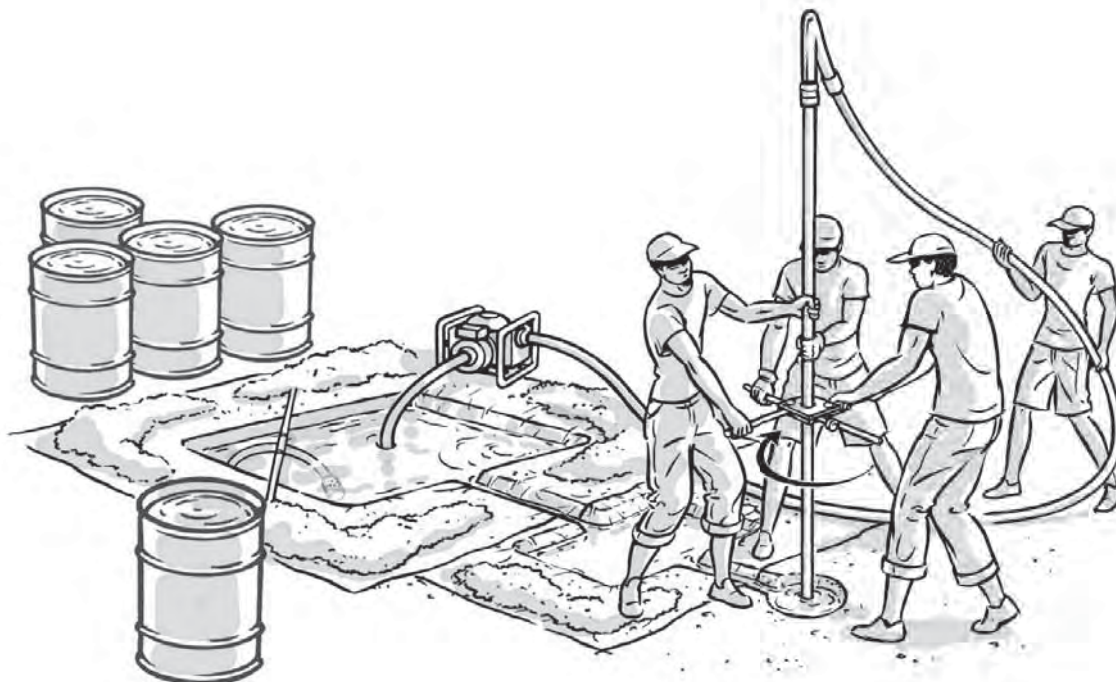

Drill a straight borehole!

Start to drill slowly. In the first meters of drilling, 2 workers should look at the drilling pipe from different angles to keep the pipe straight (if only 1 worker is checking the drilling pipe, there is still a chance that the borehole will not be straight).

A borehole which is not straight will cause problems later during installation of the well casing and the hand pump.

How to drill

The drilling movement is a combination of rotation and downward pressure, making the drilling bit cut downwards and clockwise.

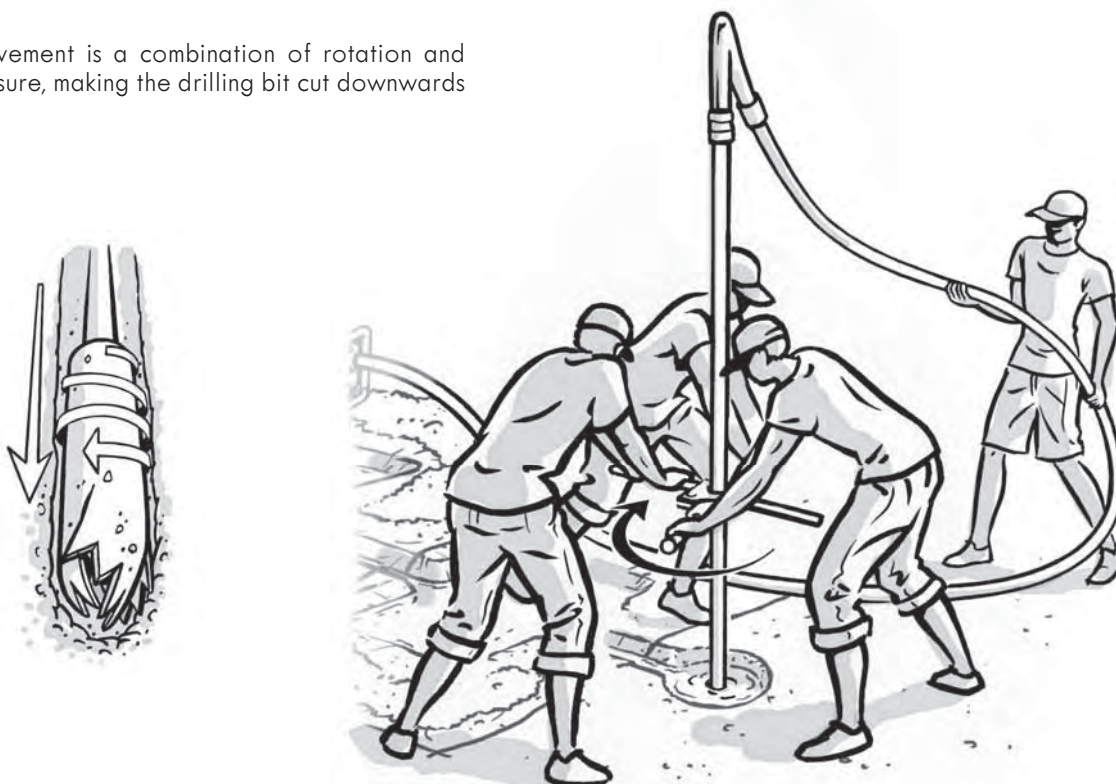

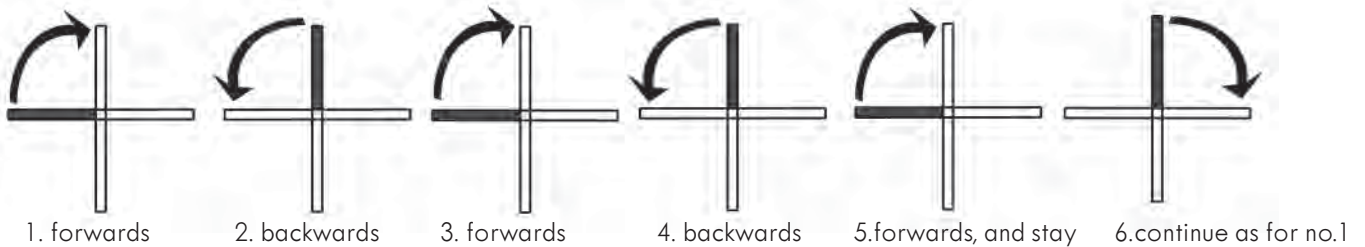
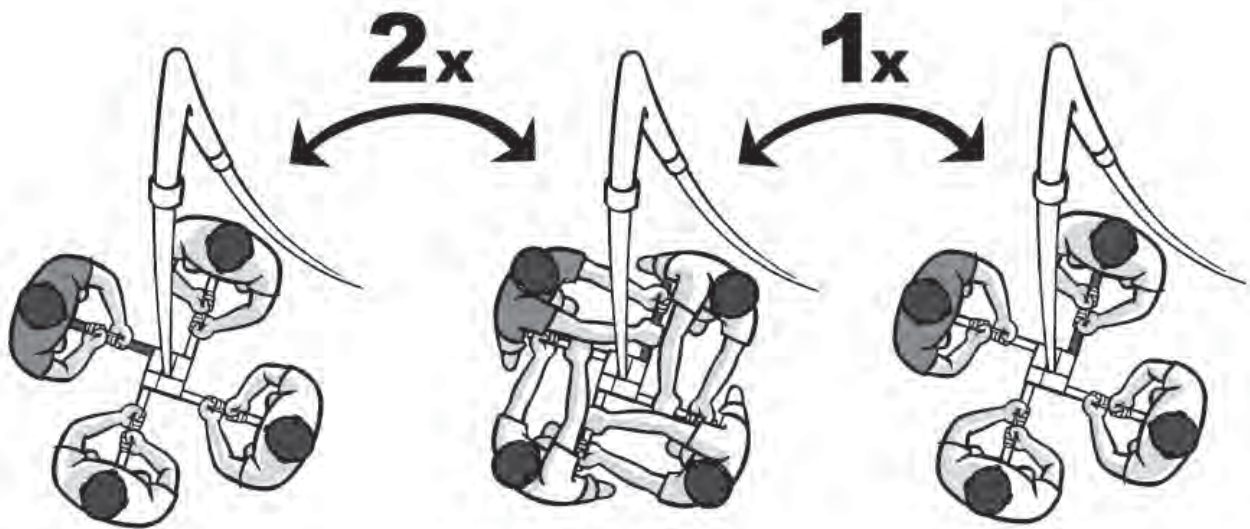

The rotation movement

- 1) Each team member rotates one side of the clamp a quarter of a turn in clockwise direction. Then he rotates it back to starting position. Do this 2 times.
- 2) Hereafter he rotates it once more and passes his side of the clamp to the team member on his left side.

Repeat these 2 steps continuously. During these movements, the body weight is used to push down on the clamp.

Tip!

Always use the clamp, even when drilling in soft soils is going very rapidly. Keep on rotating and lower the drilling pipe slowly. This will create enough time for the soil particles to be washed up and out of the borehole. Doing so will prevent the drilling pipes and drill bit from getting stuck.

STEP 6 MAKING A TEMPORARY STOP & ADDING A NEW DRILLING PIPE

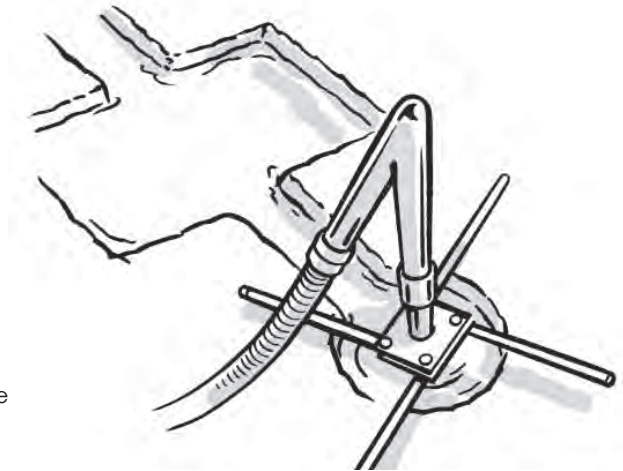

Make a temporary stop

Continue drilling until the clamp has reached the swivel and is able to rest on the ground surface.

Keep the drilling pipes in their position (do not drill deeper!) and let the water circulate continuously. This will wash out all the cuttings from the borehole.

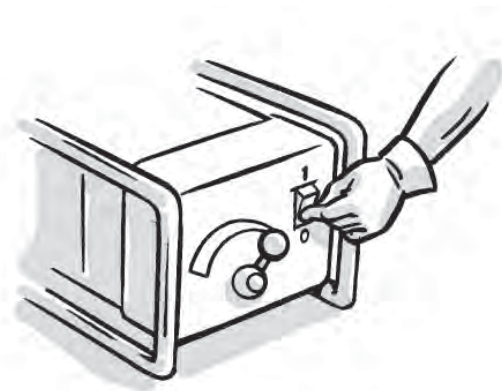

Shut down the engine

Make sure that ALL the drilled cuttings have been removed from the borehole. Check if the water that comes out of the borehole is 'clean'.

Only then it is safe to shut down the engine (and stop water circulation).

When drilling additives have been used and there is not much loss of water, the engine can be shut down safely.



Empty the mud pit

Once the engine is shut down, the cuttings can be removed from both mud pits. Be careful not to damage the plastic sheet with your shovel when you empty the mud pits.



Add a new drilling pipe

Remove the swivel from the drilling pipe in the borehole.

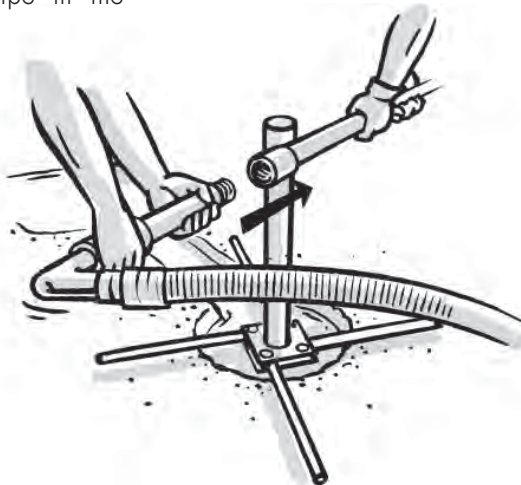

Attach the swivel to a new drilling pipe.



Add this new drilling pipe to the pipe in the borehole.

Then, place the clamp on a higher position and switch on the engine to continue drilling.

Tip!

Keep the borehole full of water at all times!

A frequently made mistake is to shut down the engine and go for lunch, without keeping an eye on your working water.

When you come back, the water level in the borehole has dropped, the hole has collapsed and your equipment is lost!

STEP 7 DRILLING TO THE RIGHT DEPTH

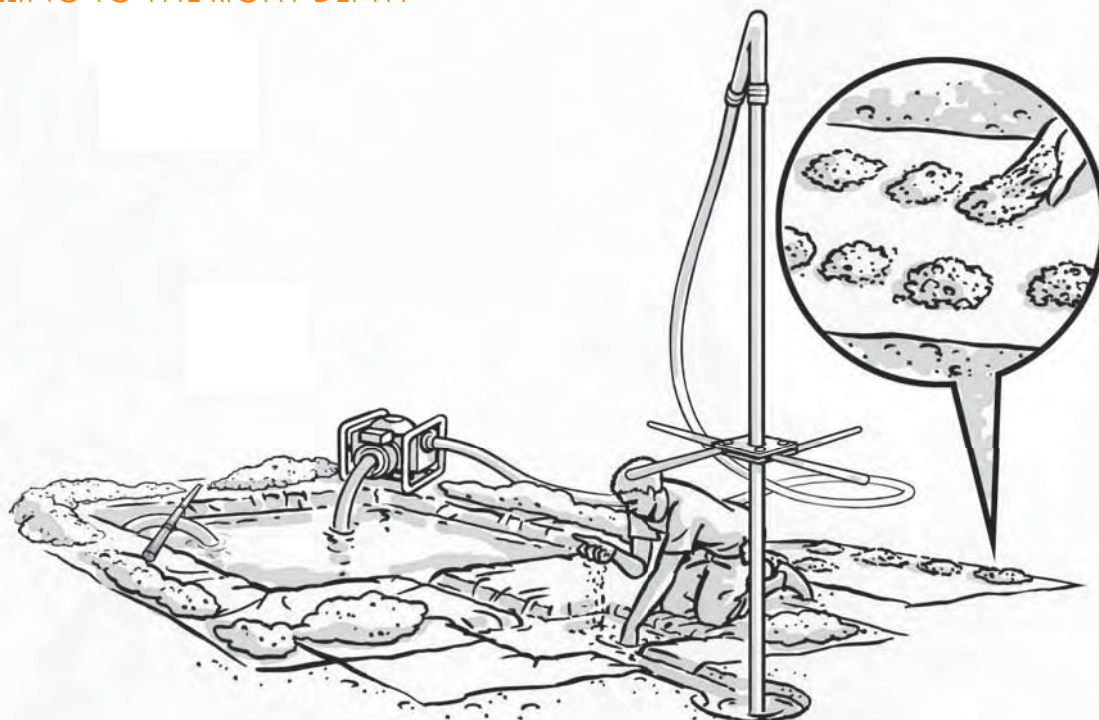

Take soil samples

Take a sample of the drilled soil, every meter or every time before a new pipe is added. Take the soil sample from the upper part of the smaller mud pit (be careful, soil can be mixed). Alternatively you can take a soil sample from the top of the borehole.

Tip!

It is very useful to place all samples on a piece of plastic and write down the depth.

The right depth of drilling

Continue drilling until you have reached the final depth. The final depth of drilling is reached when you have drilled at least 4 meter into a coarse layer of sand/gravel.

STEP 8 THE FINAL STEPS

Only continue with the next step if you have reached the final depth of drilling

Flush the well

The next step is to wash out ALL the drilled cuttings from the borehole!

Keep the drilling pipes in their position (do not drill deeper!) and let the water circulate continuously for about 5 minutes. This will wash out all the cuttings from the borehole.

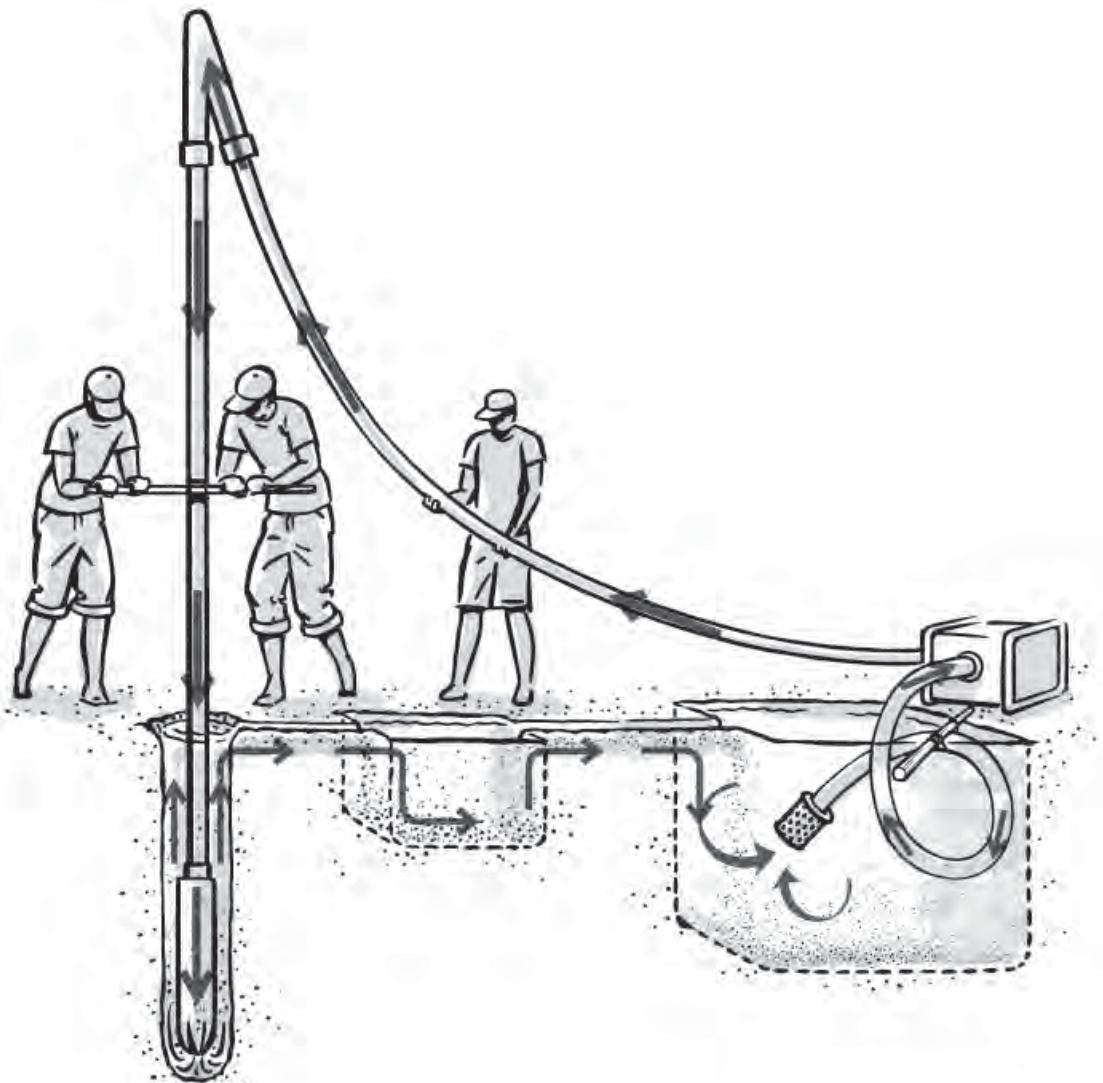

Shut down the engine

Keep circulating until ALL the drilled cuttings have been removed from the borehole. Check if the water that comes out of the borehole is 'clean'.

Only then it is safe to shut down the engine (and stop water circulation).

Remove the drilling pipes

When the borehole is clean, you can remove your drilling pipes.

Lift up one drilling pipe at the time!

1. Lift up a drilling pipe and hold it with the pipe wrench.
2. Attach the clamp at ground level to prevent the pipe from dropping back into the borehole.
3. Remove the pipe, lift up the next pipe and lower the clamp.
4. Continue until all pipes have been removed.

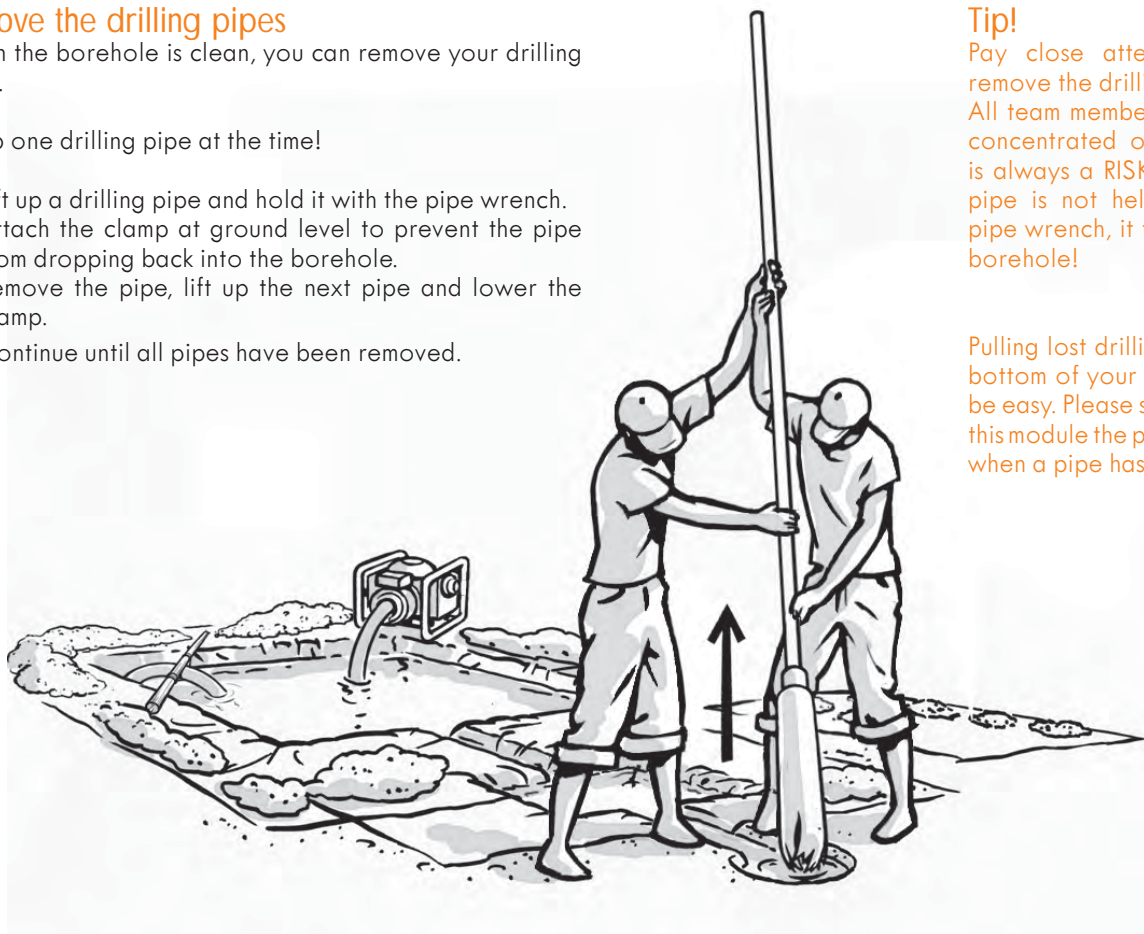

Tip!

Pay close attention when you remove the drilling pipes! All team members should be fully concentrated on the job. There is always a RISK that if a drilling pipe is not held properly by a pipe wrench, it falls back into the borehole!

Pulling lost drilling pipes from the bottom of your borehole will not be easy. Please see in chapter 5 of this module the paragraph: 'Fishing when a pipe has dropped'

Measuring the depth of drilling

Measure the exact depth of your borehole. This gives you information on the total length of casing pipes needed.

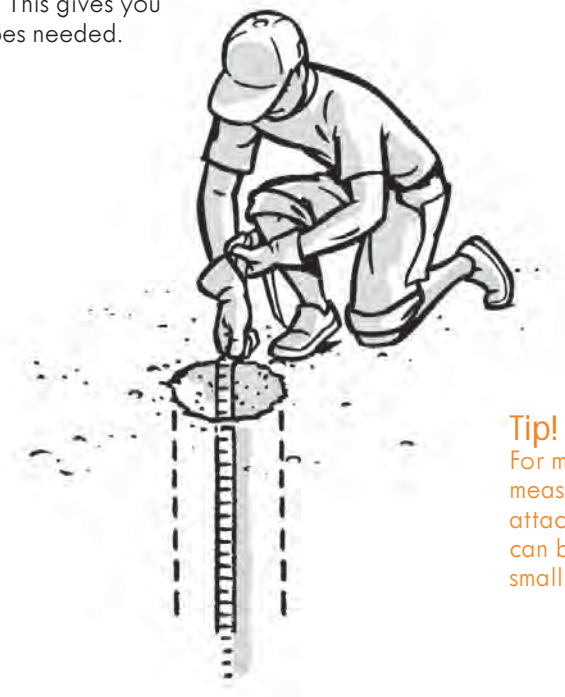

Tip!

For measuring; use a rope or long measuring tape with a small weight attached. Measuring with a rope can be best done when you make small knots at every meter.

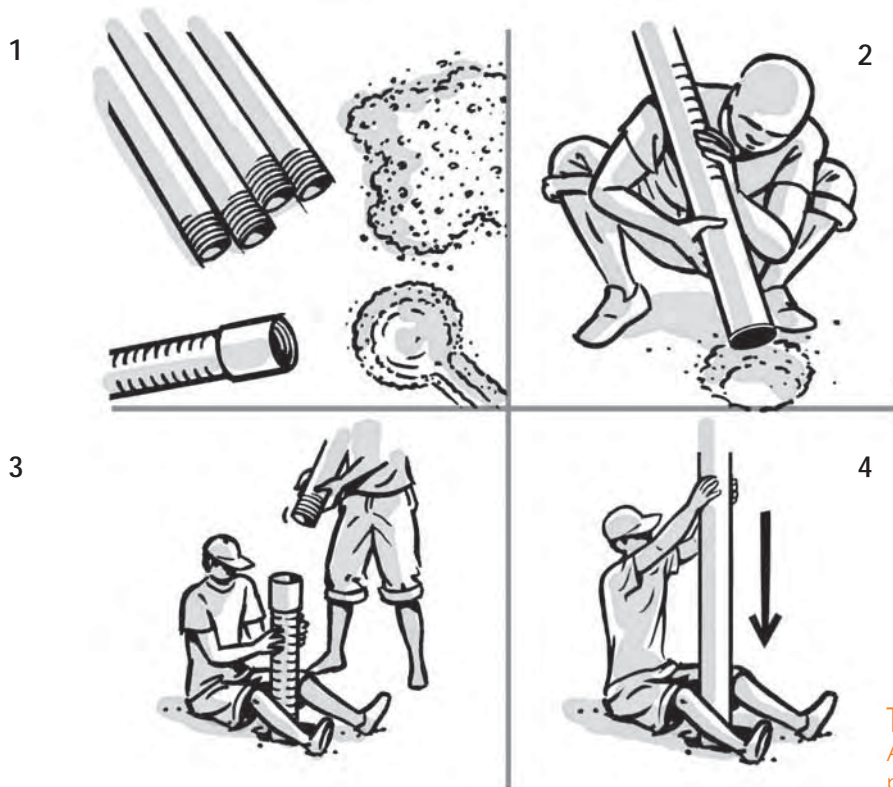

Tip!
Always make sure that one person is holding the casing to prevent it from dropping into the borehole.

Installation of the PVC casing

Prepare the filter screen, the sump and the casing, before you start the installation (1).

Lower the filter screen into the borehole (2). Then screw or glue the first PVC casing pipe to the screen (3). Lower the casing further into the borehole (4). More PVC pipes are added one by one.

Cleaning the well and the screen

When the casing and screen is installed, the borehole and screen are now further cleaned:

Drain the dirty water away from the mud pits.

Then pour clean water into the casing and allow dirty water to overflow the borehole. Only when clean water comes out of the borehole, the cleaning is finished and the gravel packing can start.





Gravel packing

Start slowly pouring in the gravel, all around the pipe. While putting the gravel in, keep moving the PVC pipe from side to side in the borehole.

Measuring the depth of the gravel pack

Measure regularly to check if the right depth of gravel packing has been reached. Fill the open space between the casing pipe and the borehole wall for 1-2 m above the top of the filter screen.

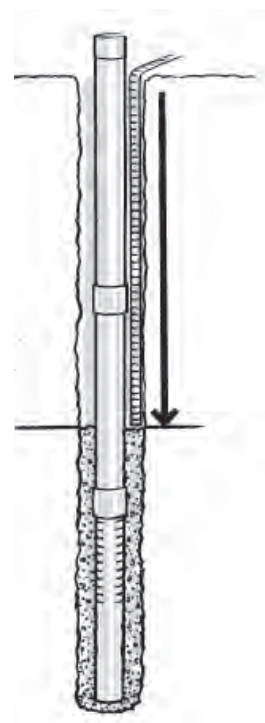

Backfilling

After you have installed the gravel pack, you must install the sanitary seal and the rest of the backfilling.

Leaving the well behind

When the drilling is finished and you are leaving the site, remember to cover the PVC casing! This can be done with a PVC cap or tightly wrapped with inner tube. This is needed to ensure that nothing can be dropped into the well by children, before the pump is installed.



5. SPECIFIC SITUATIONS AND COMMON PITFALLS

Drilling in compacted soils

If a thin layer of compacted sand or clay is encountered, a percussive (up and down) movement with the drilling pipe can be made to penetrate the soil.

Lift the clamp and drilling pipe for 30 cm. Then drop down the pipe again. The drill bit will hit the bottom of the borehole, breaking the formation. At the second lift, you now move the clamp a quarter of a turn in clockwise direction. This will change the position of the drill bit. The team member on your left takes over your side of the clamp. Then the pipe is dropped again. Continue these movements until you have passed the compacted layer.

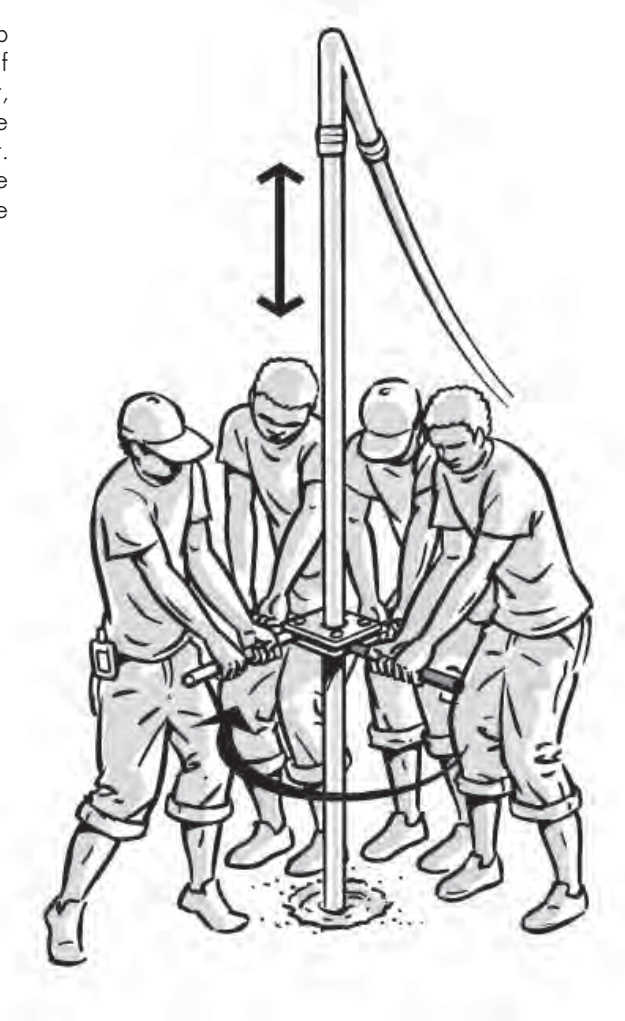

Fishing when a pipe has dropped

When a pipe has fallen back into the borehole by accident, it needs to be recovered quickly. Lower your drilling pipe slowly back into the borehole and try to find the top of the lost pipe. Carefully try to screw your drilling pipe onto the lost pipe. Then slowly lift the pipes again.

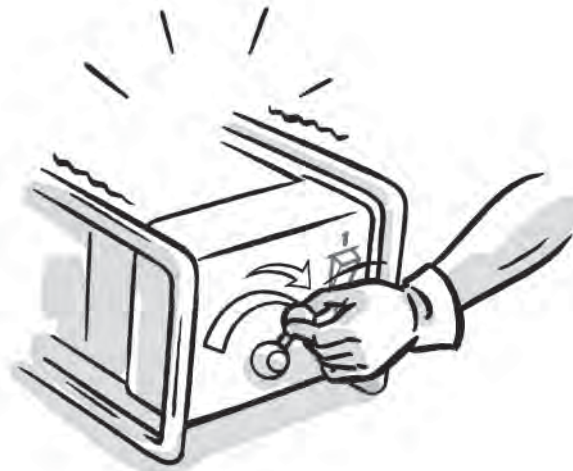

Short stops

If you have to make a short stop for any reason (for example a few minutes rest), you can lower the speed of the engine. This allows you to keep the water circulating without drilling any deeper.

Never forget!!

1. Keep your borehole full of water at all times.
2. Always choose a site at least 30 m away from a latrine and other sources of pollution.
3. If you pause drilling for a longer time (for example lunch), lift the pipe a few meters up in the borehole. This will prevent the drilling pipe from getting stuck.
4. Always take soil samples. Place them on a plastic sheet and write down the depth. This will help to determine the depth of your drilling.
5. Always place your filter screen in the coarsest layer of sand or gravel.
6. Use a sump (blind pipe) below your filter screen to collect any fine material that enters the well.
7. A guideline for the length of the filter screen is 3 meter.
8. When drilling goes very fast (1 meter in 5 minutes or less), always keep rotating the clamp and lower the speed of drilling. Your drilling pipe can get stuck when too much soil is drilled at once.
9. When the drilling is finished and you are leaving the site, remember to cover the PVC casing. This can be done with a PVC cap or a plastic bag tightly wrapped with inner tube. It is needed to assure that nothing can be dropped into the well by children.

Tool maintenance

- o Look after your drilling pipes. Keep threads clean and apply some grease to the threads. Protect threads with a PVC cap, socket or wrapping, especially during transport, to prevent damage.
- o Regularly sharpen the teeth of the drilling bit using an angle grinder.
- o Check the welds on the drilling pipe connections, swivel and clamp.
- o Inspect the flexible pipes for leakages. If found; repair them with inner tube.
- o Regularly check the drilling pipes for straightness and leakages.
- o Maintain the pump set.
- o Check if the tools are complete and replace if necessary.

6. RAPID WELL JETTING

Rapid well jetting is especially suitable for farmers or households who want very low cost wells for irrigation or drinking water, but it is also used in many places to increase the yield of hand dug wells. Rapid well jetting is used in areas where the water table is high (within 5 meter of the surface) and the soil is sandy, such as in rivers, coastal areas and floodplains of rivers. In these cases it is possible to jet rapidly without the need for rotation, a special cutting bit, additives and water circulation (no mud pits).

This technique is also called 'clear water jetting' or 'farmer jetting' or 'wash bore'. The maximum drilling depth is 6 - 10 meters. This chapter gives a description of a generalized method, but there are many variations of rapid well jetting for particular situations.

STEP 1 PREPERATION

The equipment you need:

- a) 5 drums (200l) full of water (or a 1m³ dug reservoir)
- b) A suction hose with filter and a delivery hose
- c) A motor pump set
- d) A jetting pipe: a single 50 mm PVC pipe, at least 4mm wall thickness
- e) Connection between delivery hose and jetting pipe: 45 degree PVC elbow
- f) A simple hand auger
- g) Well casing: 63 to 100 mm PVC casing pipe

Connect the suction hose and the delivery hose to the pump and connect the delivery hose to the jetting pipe. In Rapid well jetting there are no mud pits. Only a starter hole is dug.



Drill a starter hole

Drill a 2 meter starter hole with the hand auger.

STEP 2 MAKE A TEST JET

What is a test jet?

A test jet is a quick drilling (to a maximum depth of 10 meter or the length of your jetting pipe). A test jet is done to find a coarse layer of sand or gravel and identify its depth. At this depth the filter screen will be placed during the final drilling. After the quick test jet, the jetting pipe is removed from the borehole.



Make a test jet

Start the engine. Place the jetting pipe in the starter hole once the water is running. Now jet (drill) down the whole length of your jetting pipe.

Tip!

Make sure that the end of the suction hose (with filter) is ALWAYS held UNDER water in the drum or reservoir! Do NOT stop the pump during drilling!

How to assure continues pumping;

- o Make sure to have people standing in line that can re-fill the drum with buckets during drilling.
- o If there are no people around that can help you to re-fill the same drum, you can dig a 1m³ reservoir.

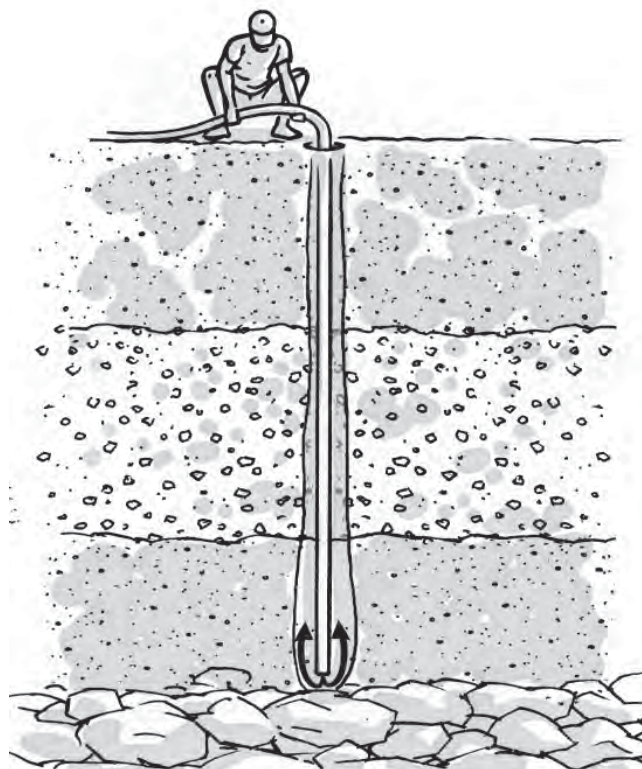

Finding a coarse layer

While drilling down, you may hear a rattling sound. This is the material that hits your jetting pipe. The sound indicates how coarse the soil is. Large material such as gravel will make a stronger rattling sound than fine sand.

Tip!

Take samples of the soil and write down the depth of the coarse soil layer.

Do NOT stop the pump!

Remove the jetting pipe

Keep the pump running and remove the jetting pipe. Then shut down the pump

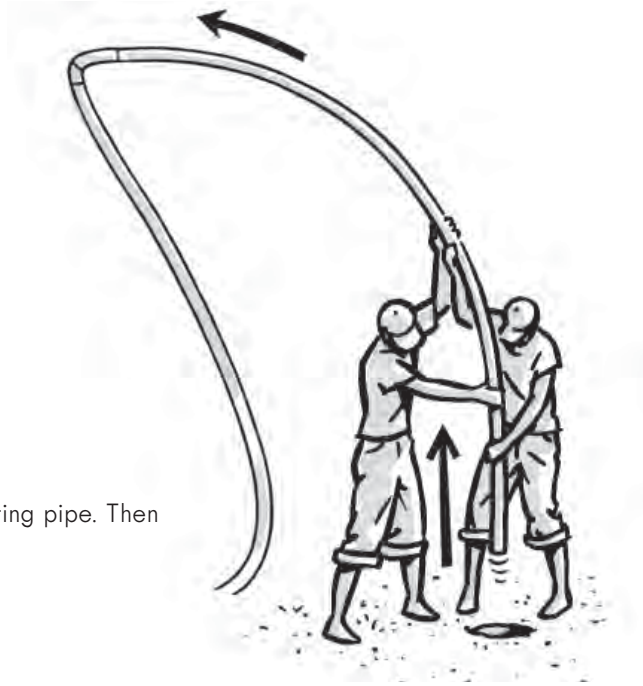

STEP 3 MAKE THE FILTER SCREEN AND CASING

Once you have identified the drilling depth, you prepare the filter screen and casing:

Take the PVC casing pipe, and make a filter screen. The length of the filter screen will depend on how coarse the sand is in the aquifer. A guideline is 0.5 meter in coarse gravel to 3 meter in fine sand, with a 20 centimeter sump at the bottom.

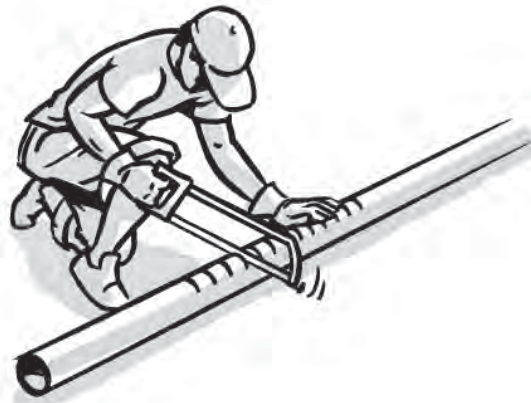

Wrap a geo-textile 3 times tightly around the filter screen. Tie on the geo-textile with nylon string or cord in a spiral.

Tip!

In very coarse sand, you do not need any geo-textile and can use the filter screen by itself, but where there is fine sand geo-textile is essential.

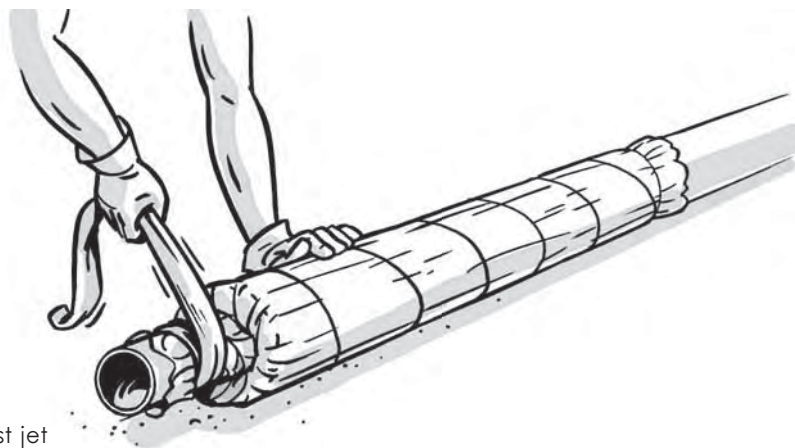

Take the jetting pipe which was used during the test jet and place it inside the casing and filter screen. Let the jetting pipe stick out for 15 cm at the bottom. Wrap the geo-textile firmly to the jetting pipe with inner tube. Then wrap the top of the casing to the jetting pipe with inner tube.

STEP 4 DRILLING THE BOREHOLE

Start the engine pump and place the jetting pipe, with the casing attached, in the same starter hole.

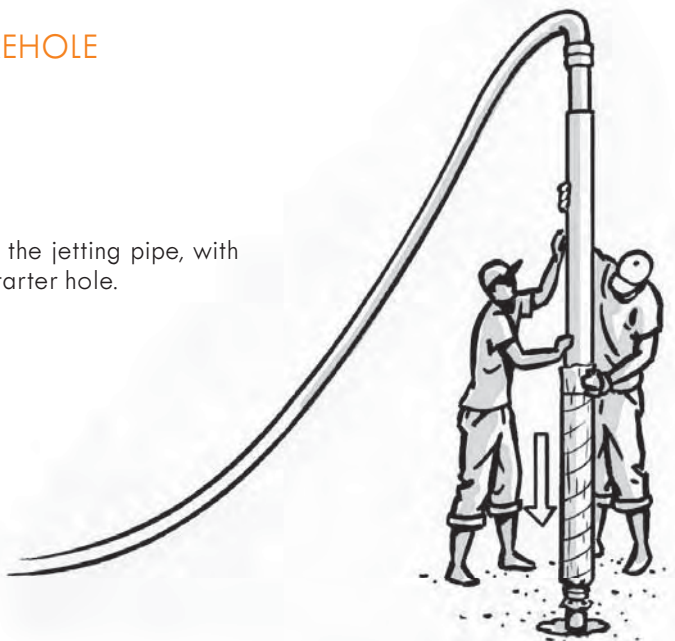

Wash the jetting pipe down until you reach the depth you have identified with the test jet

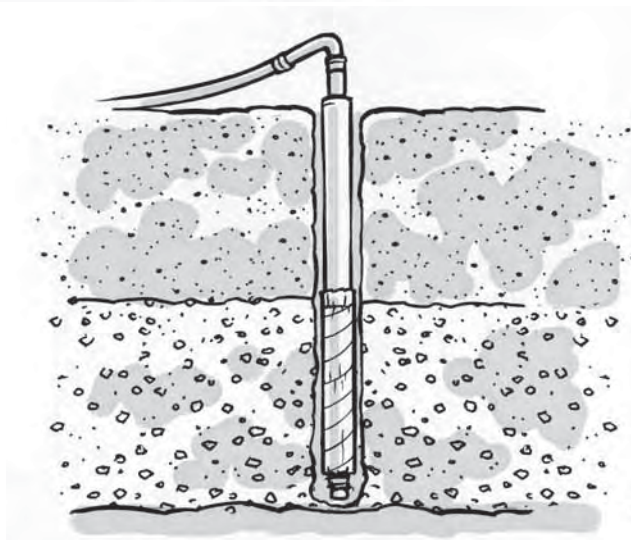

Continue pumping for a short time to wash up the fines.

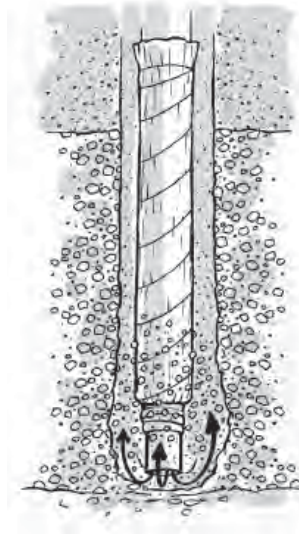

STEP 5 FINISHING THE WELL

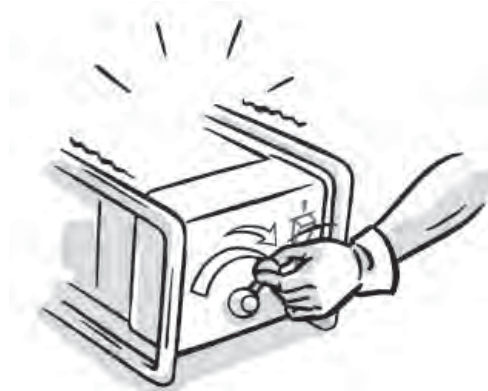

Creating a natural 'gravel pack'

Reduce the engine speed very gradually until it stops. The fine soil particles will be washed up, while the coarse soil particles stay down. This ensures that a natural gravel pack will be formed around the filter screen automatically.

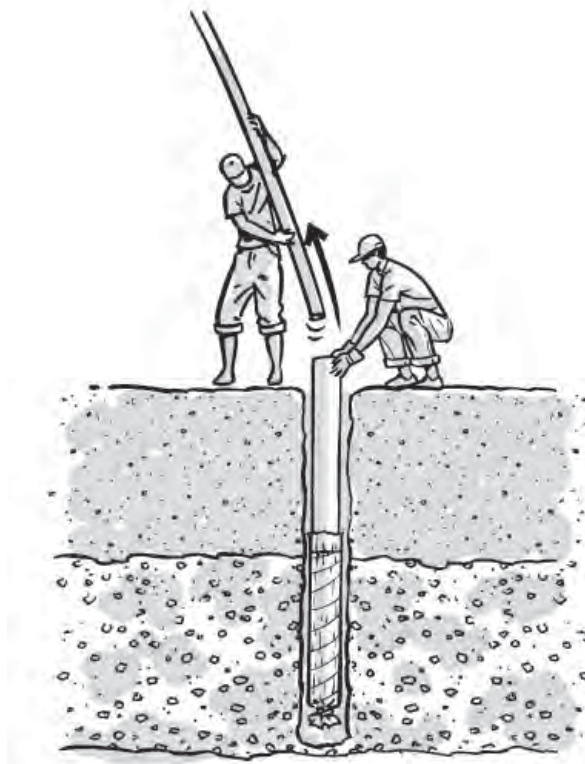

Remove the jetting pipe

Keep the casing in place, while you carefully pull out the jetting pipe from the casing.

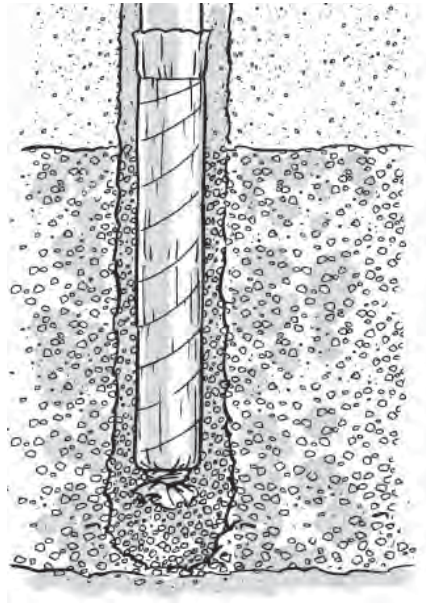

The inner tube will close the geo-textile at bottom automatically. To be extra safe; you can make a plug from a bag of sand and drop it down to ensure that the bottom is totally closed.



Backfilling

Now this is done, you can install the rest of the backfilling

Leaving the well behind

When the drilling is finished and you are leaving the site, remember to cover the PVC casing!

This can be done with a PVC cap or tightly wrapped with inner tube. It is needed to ensure that nothing can be dropped into the well by children.

JETTING

Module 3

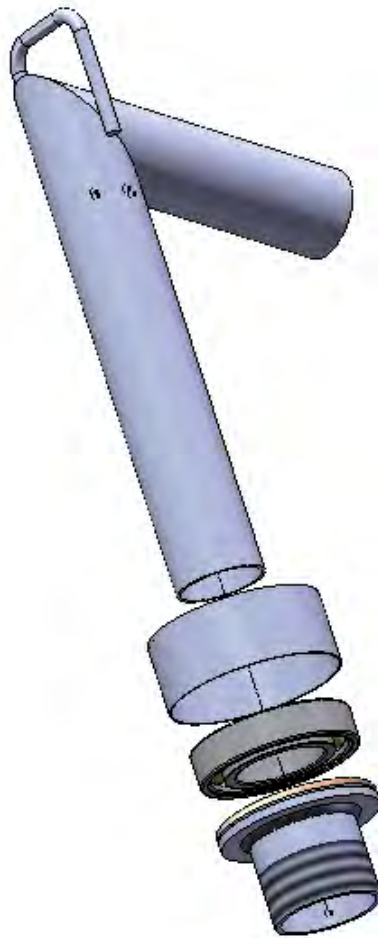

MAKING THE DRILLING EQUIPMENT

1. WHAT TO BUY

This module explains how to fabricate all drilling equipment. It consists of a material list for the drilling equipment and tools and a package of technical drawings, including tips that are necessary to make a complete drilling set.

Material list for the construction of drilling equipment

Equipment	Part	Material	Dimension (mm)	Thickness	Amount	Additional information
Jetting clamp	handle bar	galvanised steel	pipe Ø 35 x 400	≥ 3	4	shock absorbers from motorbikes can be used
	hingeplate	galvanised steel	plate 75 x 30	8	2	
	baseplate	galvanised steel	plate 210 x 95	15	2	
	hinge connector	galvanised steel	plate 215 x 30	8	1	
	bolt	steel	bolt M8 x 50	8	4	
	nut	steel	Nut M8		4	
	clamp key	galvanised steel	bar 8 x 130	8	1	
	nut	steel	nut M10		1	
Jetting pipe	drilling pipe	galvanised steel	pipe 2" x 1000	5	1	notice the wallthickness
	drilling pipe	galvanised steel	pipe 2" x 6000	3	5	notice the wallthickness
	round bar	galvanised steel	bar 6 x 6000	6	1	
	coupling	galvanised steel	coupling 2"	5	10	
Jetting bit	bit	galvanised steel	pipe Ø 115 x 500	7	1	It is possible to use a thick metal plate, but much more difficult to bend into a circle thickness in the range of 4-7 mm
	coupling	galvanised steel	coupling 2"	5	1	
	cover plate	galvanised steel	plate Ø 100	7	1	
Jetting swivel	pipe	galvanised steel	pipe Ø 50 x 500	3	1	
	bearing	galvanised steel	bearing Ø 90 x Ø 50	20	1	SKF 6210
	connection	galvanised steel	plate Ø 90	5	1	
	round bar	galvanised steel	bar 6 x 550	6	1	
	bearing cover	galvanised steel	sheet metal Ø 100	1	1	
	bearing cover	galvanised steel	sheet metal 40 x 320	1	1	
	pipe	galvanised steel	pipe 2" x 50	3	1	

Purchase list for additional tools

	Part	Material	Dimension (mm)	Thickness	Amount	Additional information	
Tools	suction hose	reinforced	2"	3	2 meter	depends on pumpset dimensions	
	delivery hose	reinforced	2"	3	5 meter	depends on pumpset dimensions	
	filter	sheetmetal	2"		1	fitting the flexible hose	
	motor pump set		3.5-4.5 HP		1	standard type	
	hacksaw				2		
	wrenches		24"		3	high quality	
	shovel				1		
	toolbox (full)				1	basic use (rope, glue, spanners, measuring tape etc.)	
	measuring tool	metal		pipe Ø 50 x 80	3	1	
		metal		bar 8 x 1000	8	1	
	inner tube	rubber				2m	
	sieves			mesh 1mm and 3mm		2	
	tarp	plastic		sheet 4000 x 6000		1	(plastic sheet)
	buckets	plastic		12 liters		2	
	oil drums	metal		200 liters		5	depending on available water source
	oil + gasoline					1 + 5 liters	pump set specific
	Materials	pvc casing					Size depends on pump/user requirements
gravel pack additives			1 mm and 3 mm		50 kg		
					1 bag	Any brand (varies in each country)	

2. TIPS FOR CONSTRUCTION

Read the following tips together with the technical drawings at the end of this module. These tips will help you in the fabrication of the drilling pipes, the drill bit and the measuring tool. The other drilling equipment can be made with the technical drawings only.

TIPS FOR MAKING THE DRILLING PIPES

(To be used by construction of drawing nr: 003 & 004)



How to weld the coupling

The thin wall pipe needs to be threaded on one side. Then, screw the steel coupling completely on this thread and weld the coupling to the thin wall pipe.

How to weld the thick wall pipe

Take a short piece of thick wall pipe and make threads on one side. Now weld the opposite side to the thin wall pipe. Be careful: It is very important that they are centered properly!

Tip: A good tool to make is a mould (welding jig) as shown in the picture. The mould consists of two pieces of angle iron welded inline on a solid base (1). The thin wall pipe (2) and the short piece thick wall pipe can now be placed in the mould (3). Shift the two pipes to each other (4). Then weld the two pieces together, all around (5). This will assure a straight connection.

Tip: Make sure the threads are greased to protect the threads during welding (welding spatters).

The drilling pipes

Thin wall drilling pipes are cheap and great in use, but when intensively used they break at the threaded connections! To overcome this problem:

- Screw a regular steel coupling on the one side of the thin wall pipe and weld it.
- Weld a short piece of thicker wall pipe with threads to the other side of the thin wall pipe.

TIPS FOR MAKING THE DRILL BIT

(To be used by construction of drawing nr: 005 & 006)

If pipe with a diameter 115 mm and wall thickness 7 mm is not available in the markets or scrap yards, there are other ways to make the drill bit.

First, see if you can find something similar such as a pipe with a diameter between 110 – 120 mm and a wall thickness between 5-7 mm.

If this is not possible, try to find a galvanized plate of 500 x 350 mm with a thickness of 5-7mm. Although much more time consuming, a blacksmith should be able to heat up this plate and bend it into a pipe.

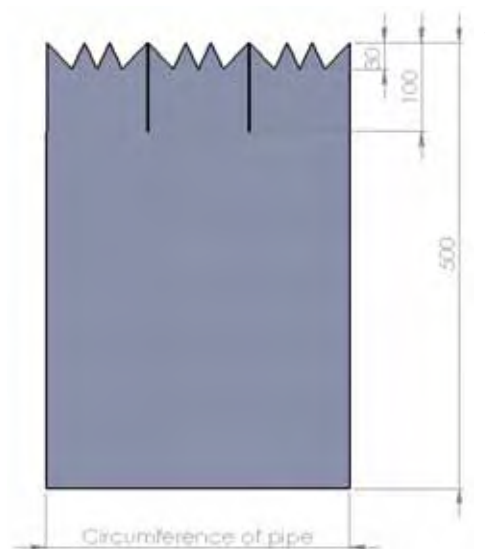

Making it out of a plate

Use a grinder to make two cuts of 100 mm and make the teeth (1). Bend the three pieces inwards and outwards as shown in the technical drawings. Now the plate should be heated and bent into a pipe and welded.

Making it out of a pipe

- use a grinder to make three cuts of 100 mm.
- make the teeth.
- bend the three pieces inwards and outwards as shown in the picture (2) and technical drawings.



TIPS FOR MAKING THE DEPTH MEASURING TOOL

Take a rope (6mm) of about 35 meters long and make knots at every meter.

Option 1: measuring the depth of the water table. Use a short piece of pipe (Ø 50 x 80 mm) and close one side, by welding on a small plate. Drill a hole in this side to attach the rope.

Option 2: measuring the depth of the gravel pack. Take the same rope, and remove the short piece of pipe that was used in option 1. Attach a long re-bar (Ø 6 x 1000 mm).



3. TECHNICAL DRAWINGS

Jetting swivel
Drawing 007, 008



Jetting pipe
Drawing 003, 004



Jetting clamp
Drawing 001, 002



Jetting bit
Drawing 005, 006

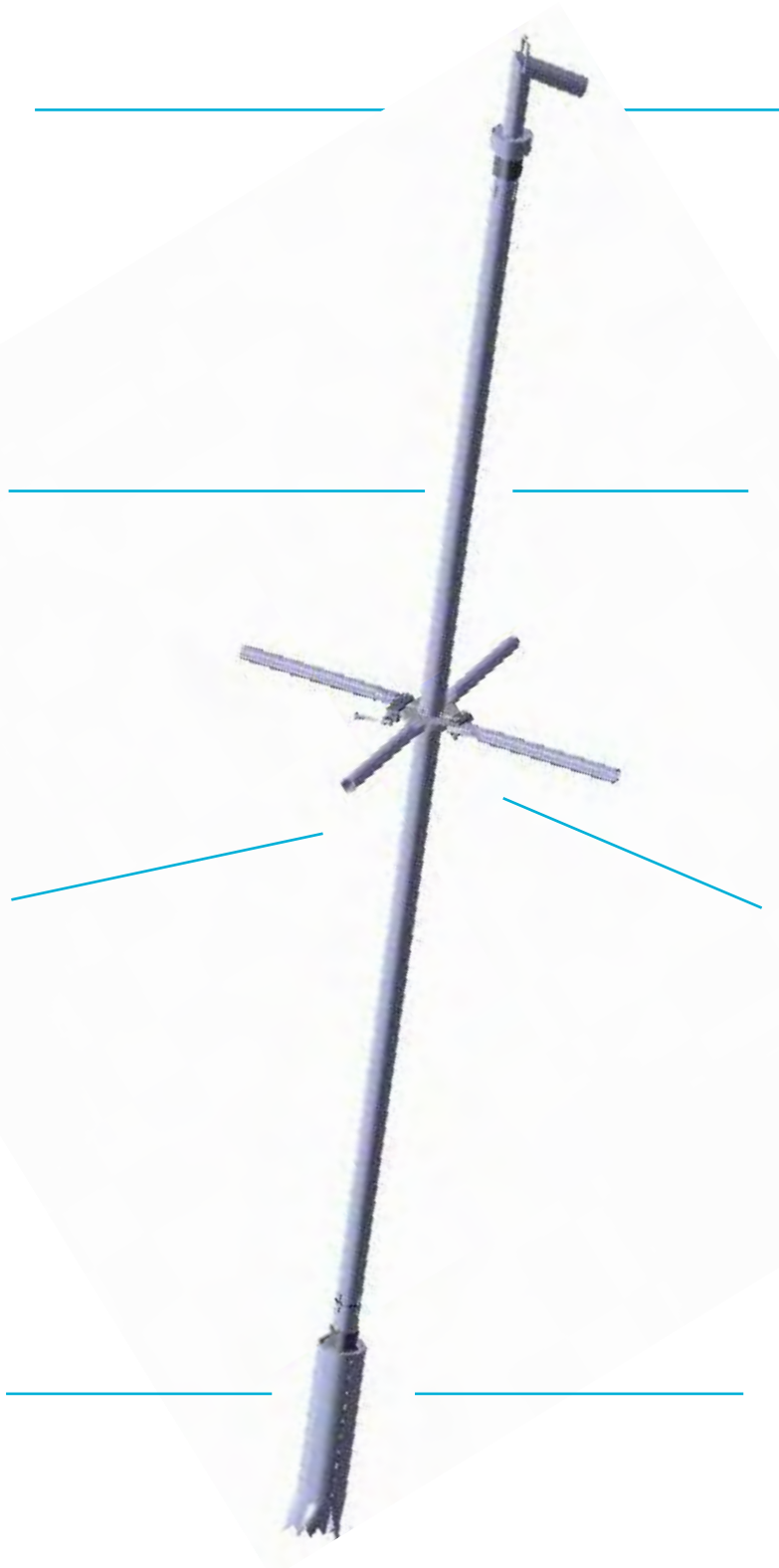

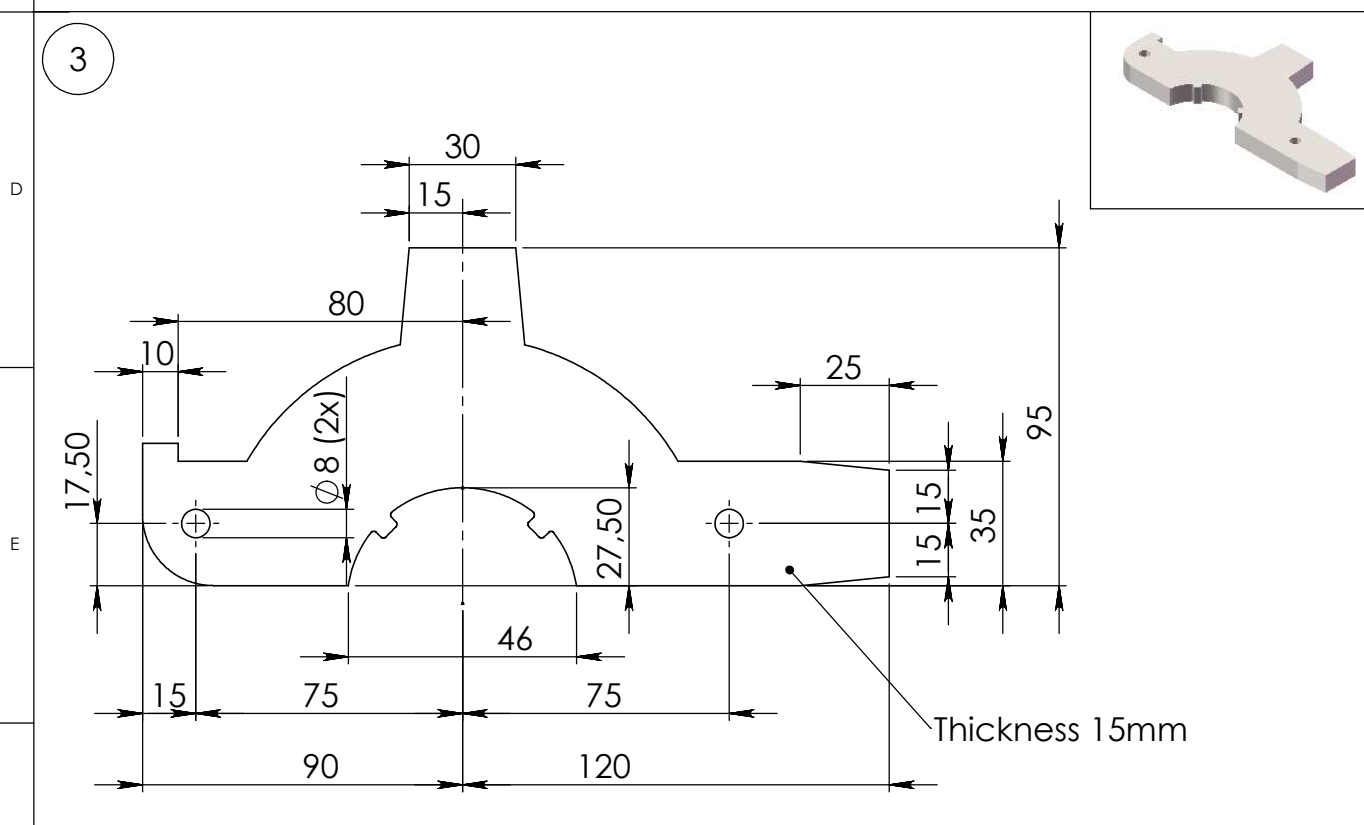
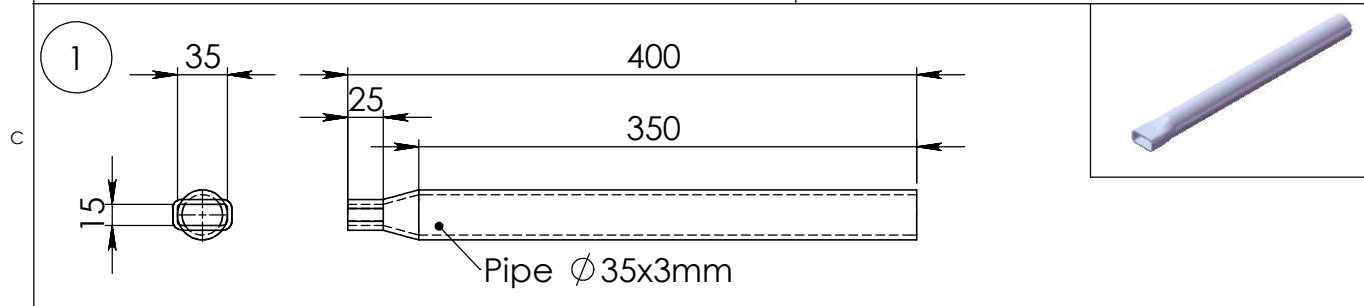
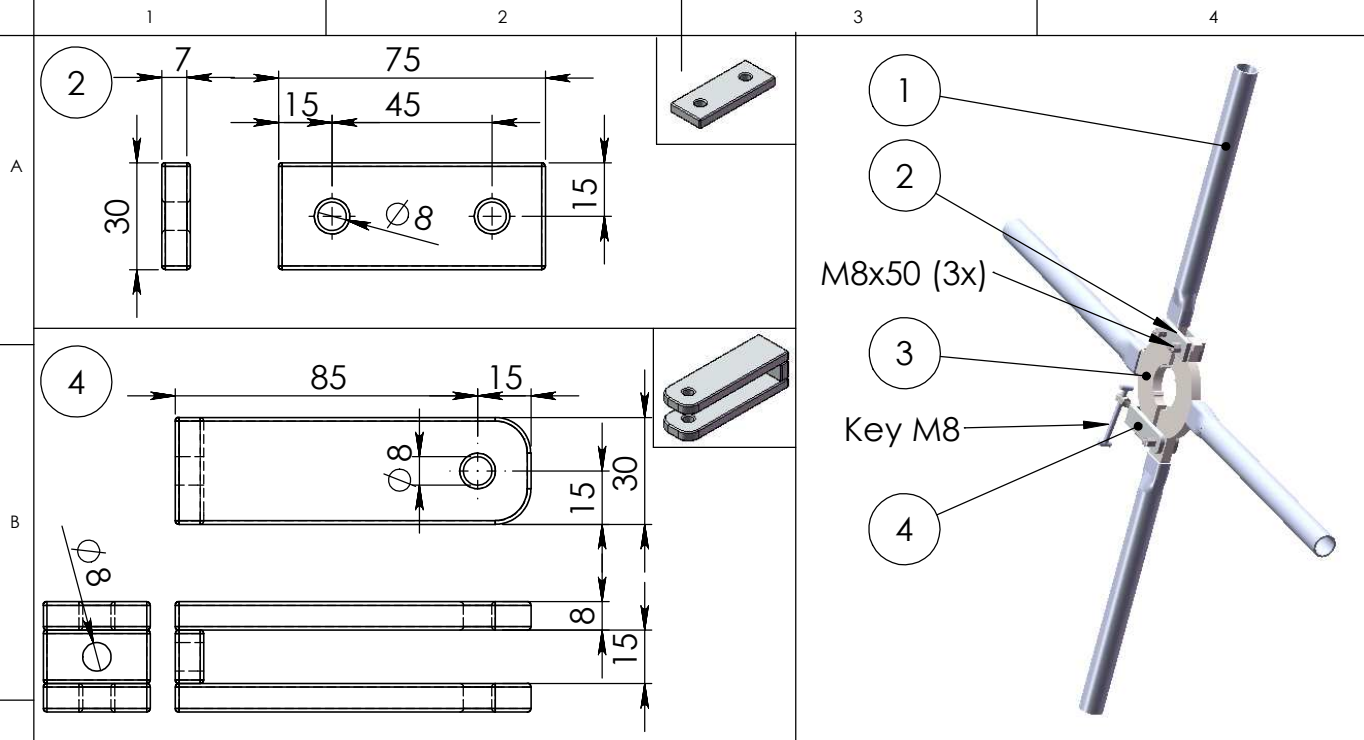

F	01	Handlebar		TITLE:		
	02	hingeplate		<h1>Jetting clamp (1)</h1>		
	03	baseplate				
	04	hinge connector				
DRAWN BY:		DATE:	VERSION:	DWG NO.	SCALE:	
Don de Koning		01-06-2010	Final v1.0	001	1:2	A4

1

2

3

4

A

B

C

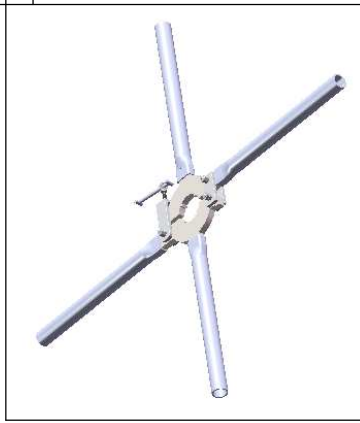
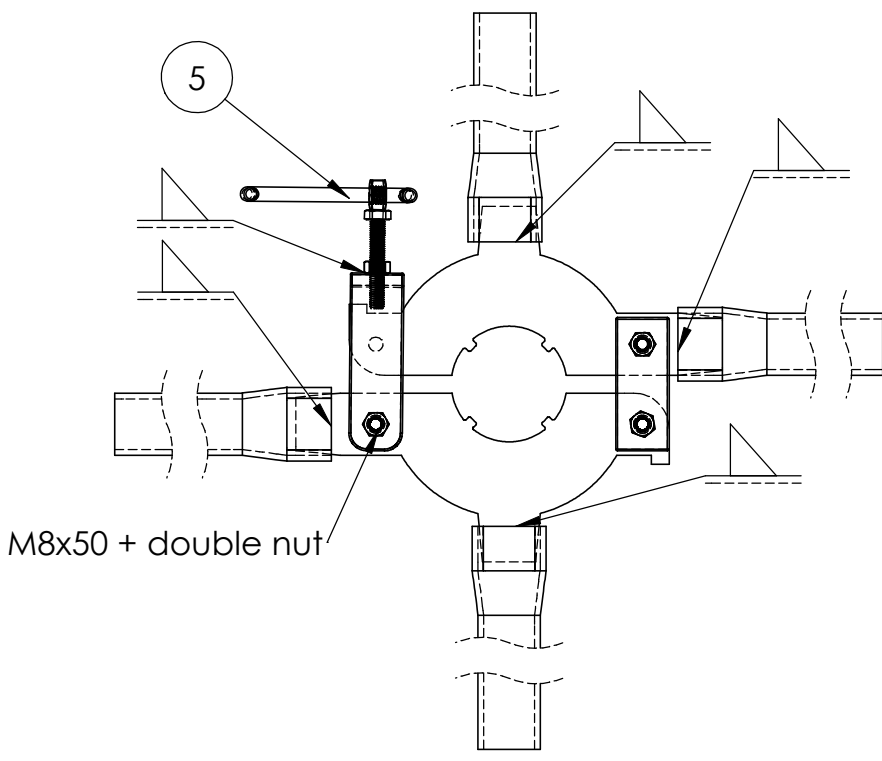

5

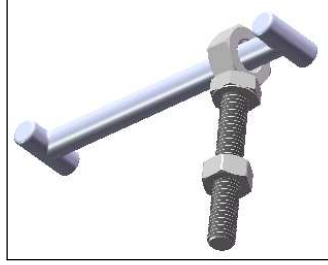
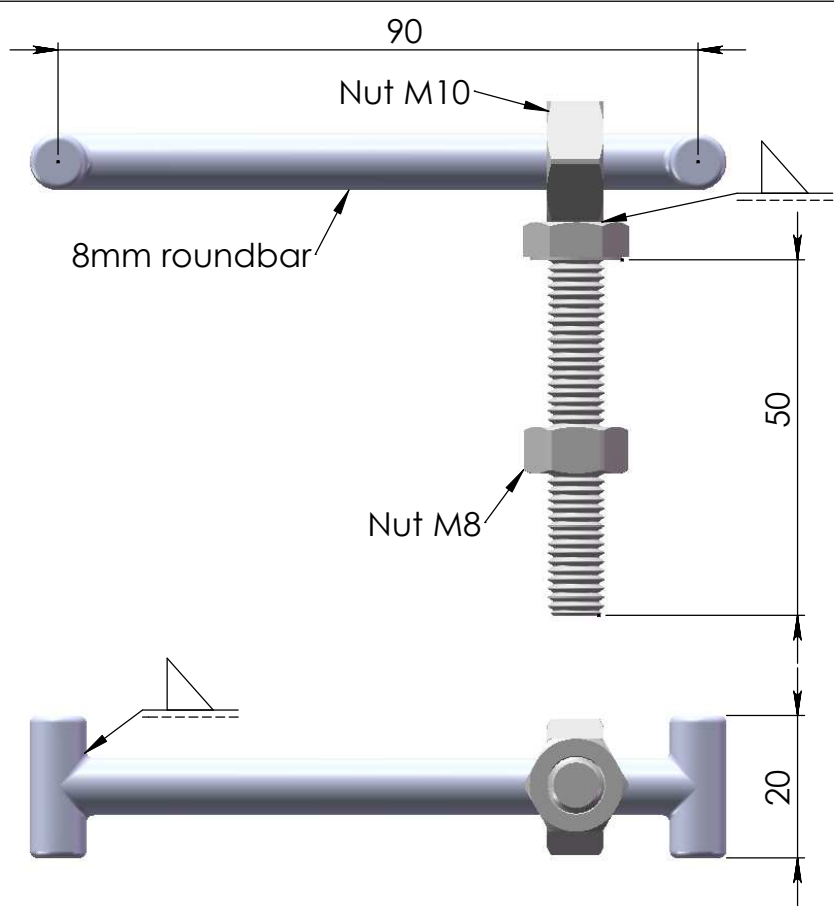

D

E

F

05	Clamp key M8



TITLE: **Jetting clamp (2)**

DRAWN BY: Don de Koning

DATE: 01-06-2010

VERSION: Final v1.0

DWG NO. **002**

SCALE: **1:1**

A4

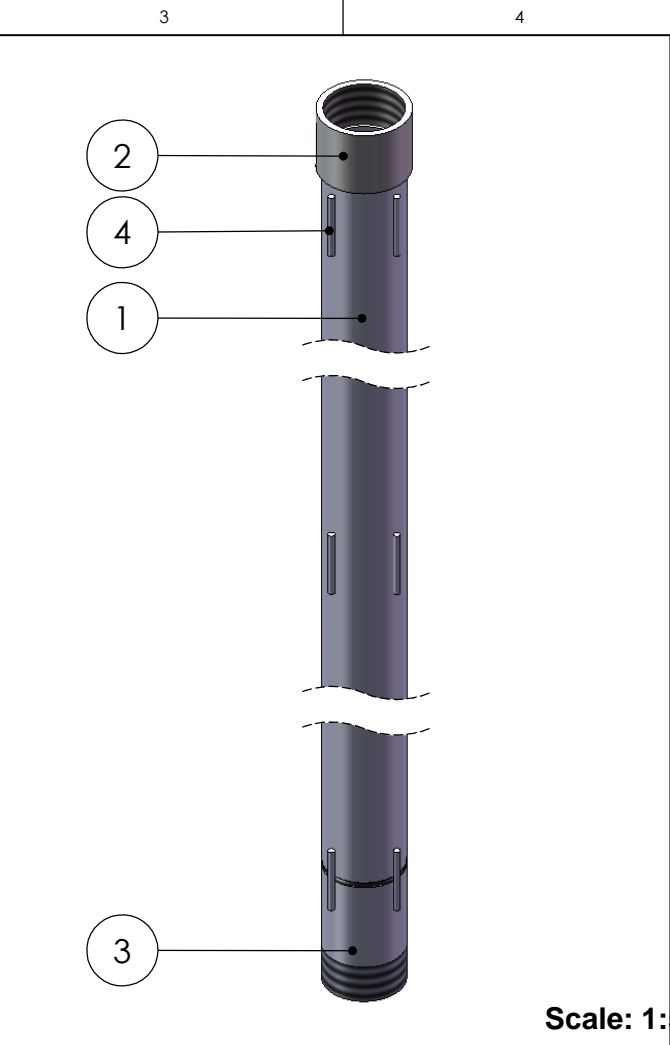
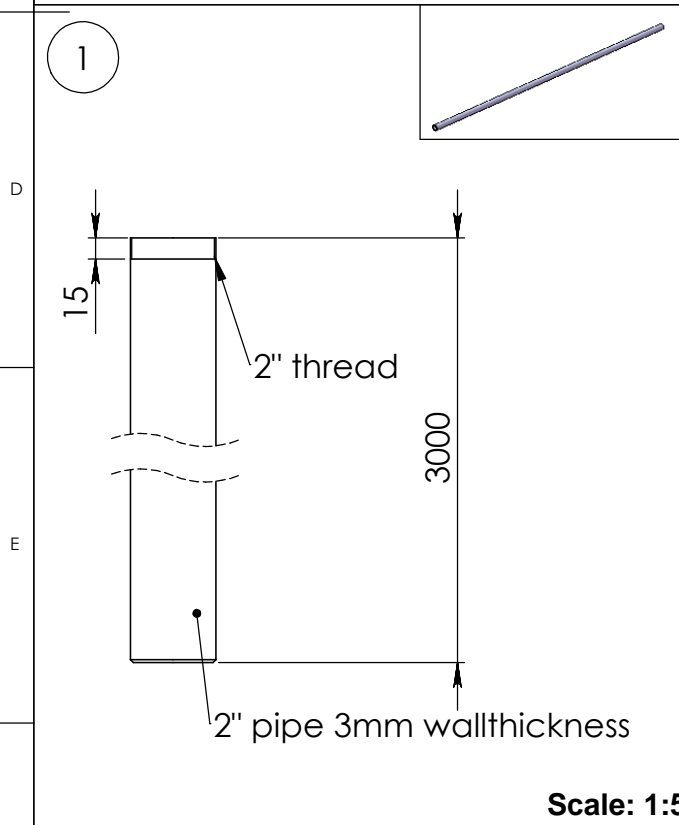
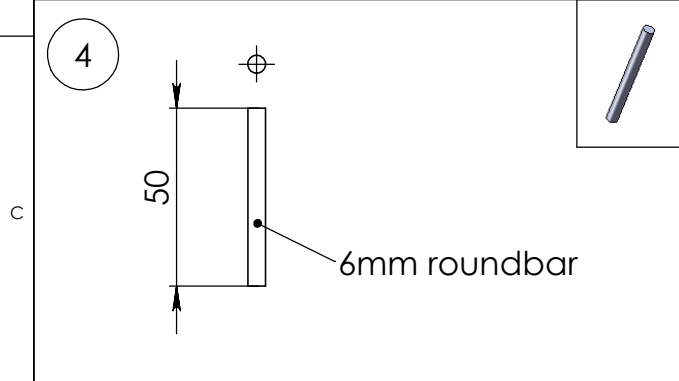
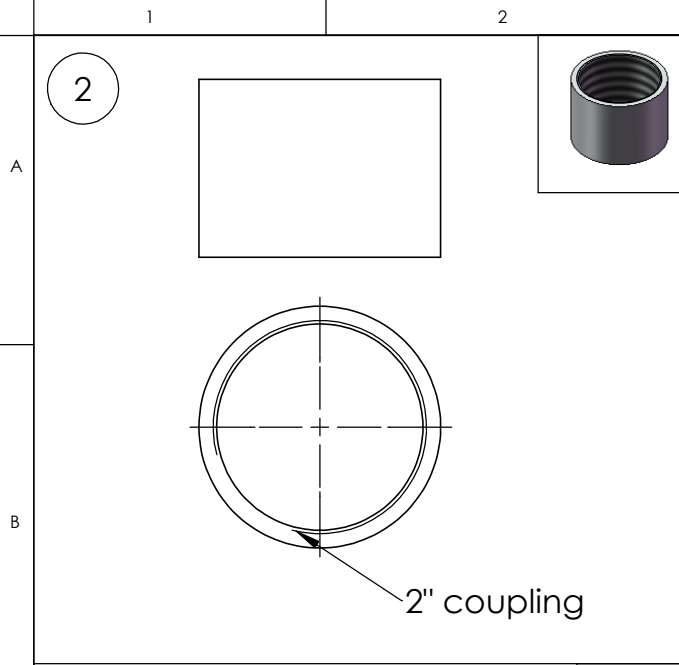

Scale: 1:5

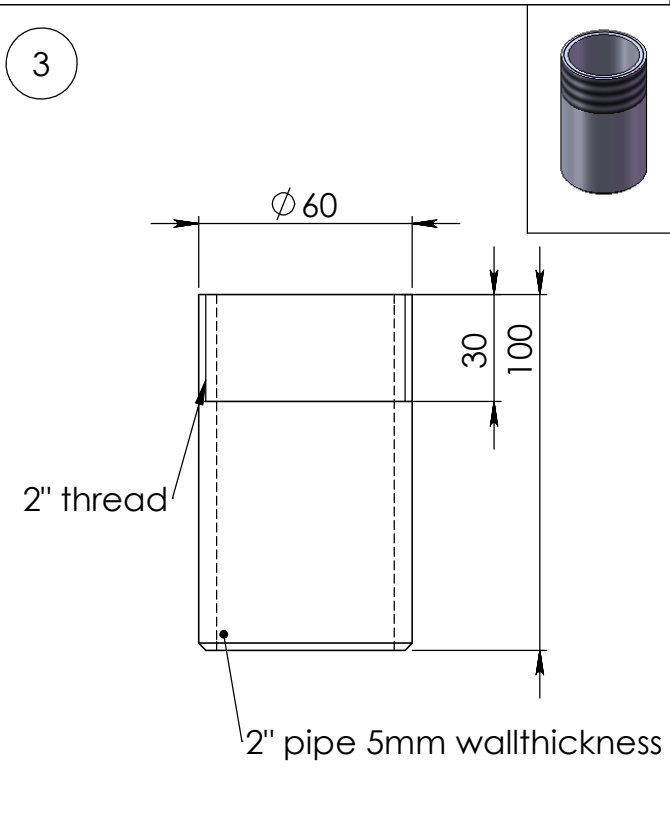

Scale: 1:5

F	01	2" pipe 2mm wallthickness		TITLE:		
	02	2" coupling		<h1>Jetting pipe (1)</h1>		
	03	2" pipe 5mm wallthickness				
	04	6mm roundbar				
DRAWN BY: Don de Koning		DATE: 01-06-2010	VERSION: Final v1.0	DWG NO. 003	SCALE: 1:2	A4

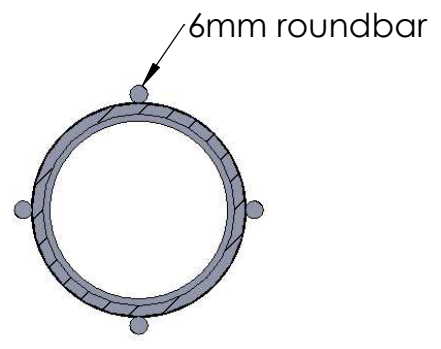
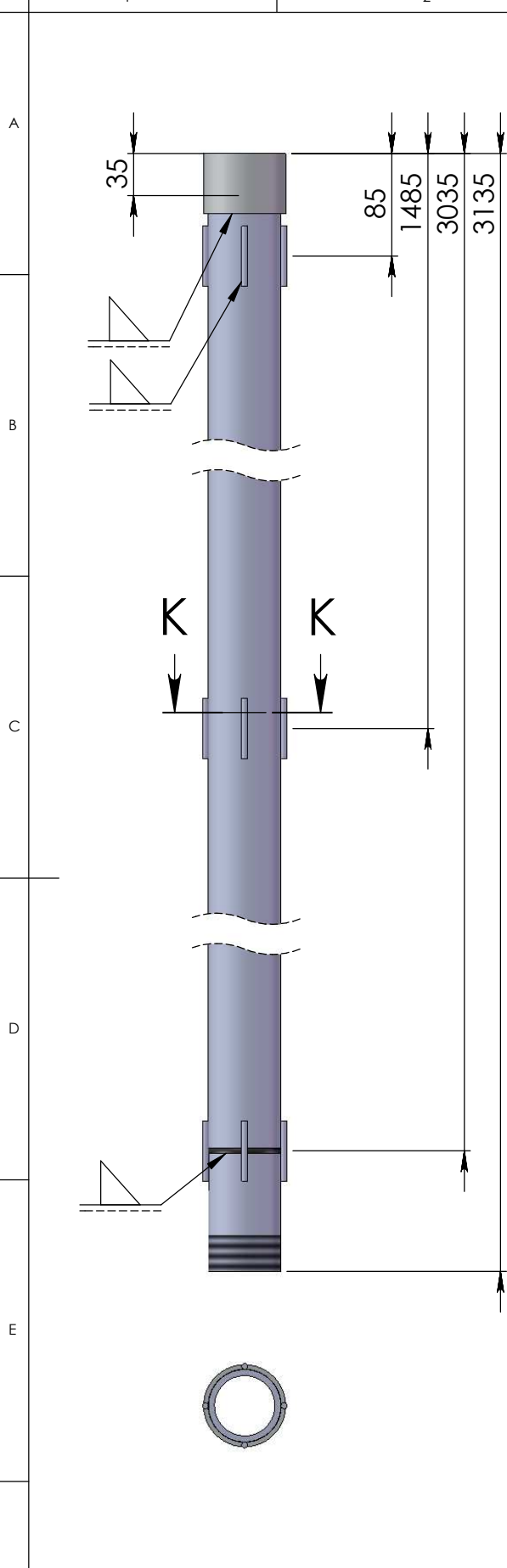

SECTION K-K
SCALE 1 : 2

F				PRACTICA <small>FOUNDATION</small>	TITLE: Jetting pipe (2)		
					DWG NO. 004	SCALE: 1:5	A4
	DRAWN BY: Don de Koning	DATE: 01-06-2010	VERSION: Final v1.0				

1

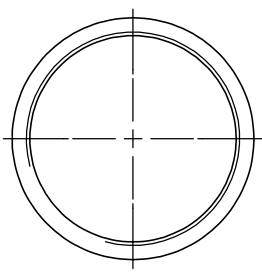

A

B

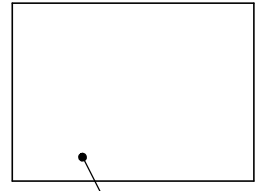

2"coupling

Scale: 1:2

2

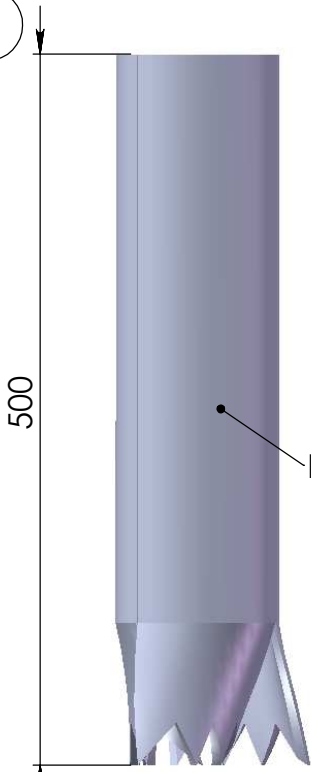

500

Pipe $\phi 115 \times 7 \text{mm}$



C

D

E

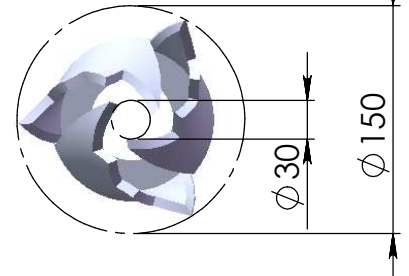

$\phi 30$

$\phi 150$

3

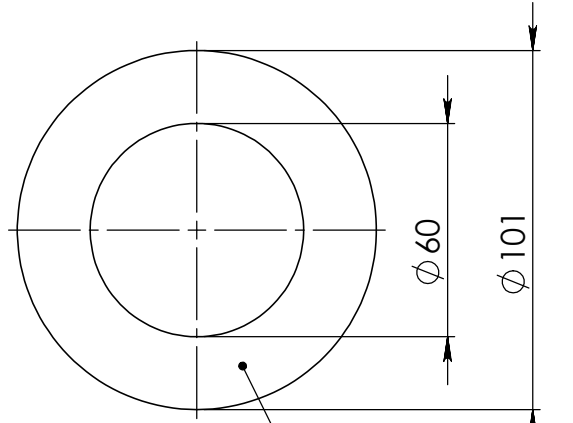

$\phi 60$

$\phi 101$

7mm sheetmetal

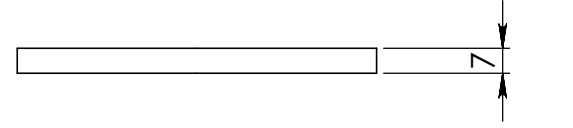

Scale: 1:2

F

01	2" coupling
02	Cover plate
03	bit

PRACTICA
FOUNDATION

TITLE: **Jetting bit (1)**

DRAWN BY: Don de Koning

DATE: 01-06-2010

VERSION: Final v1.0

DWG NO.

005

SCALE:

1:5

A4

1

2

3

4

A

B

C

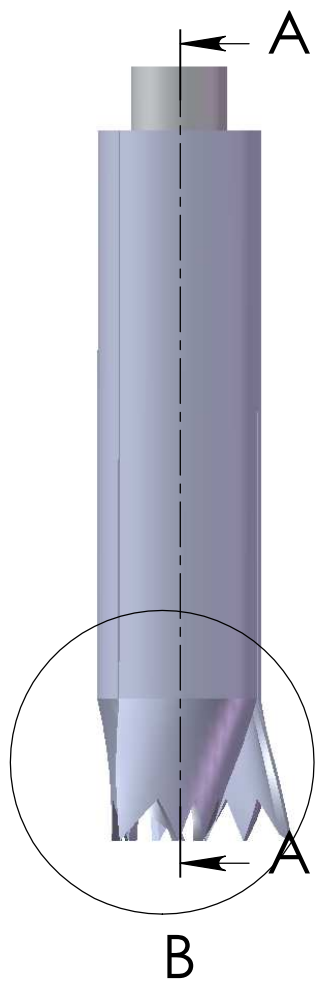

C

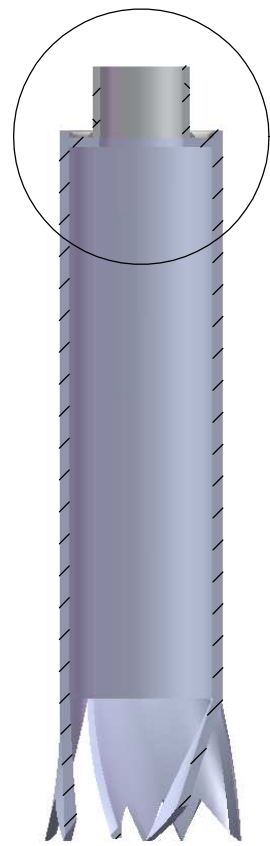

SECTION A-A

D

E

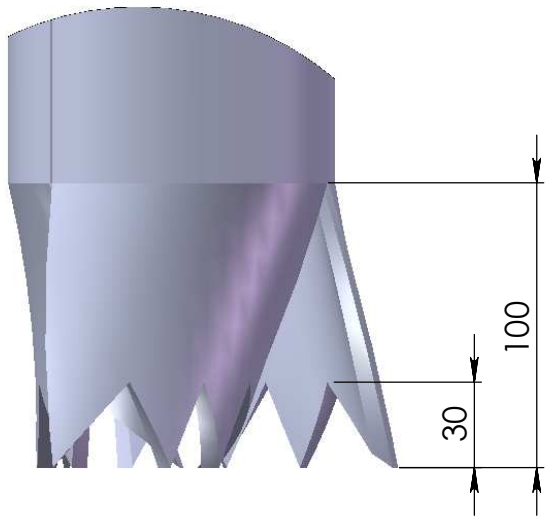

DETAIL B
SCALE 2 : 5

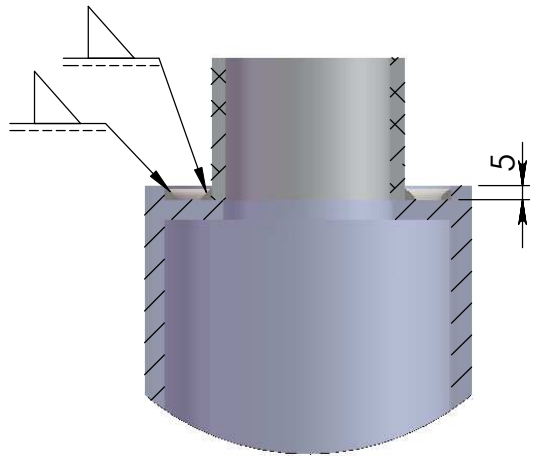

DETAIL C
SCALE 2 : 5

F



TITLE:

Jetting bit (2)

DRAWN BY:
Don de Koning

DATE:
01-06-2010

VERSION:
Final v1.0

DWG NO.
006

SCALE:
1:5

A4

1

A

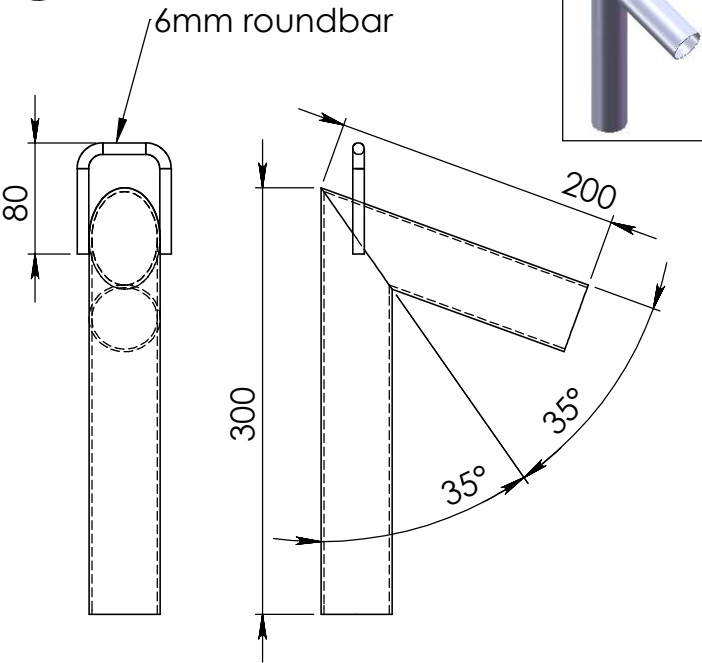

1

2

3

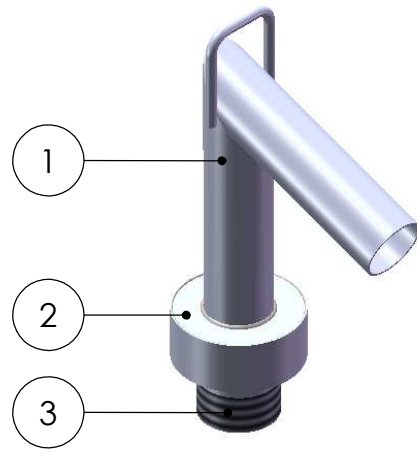

C

2

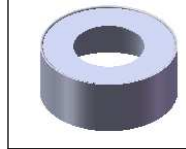

D

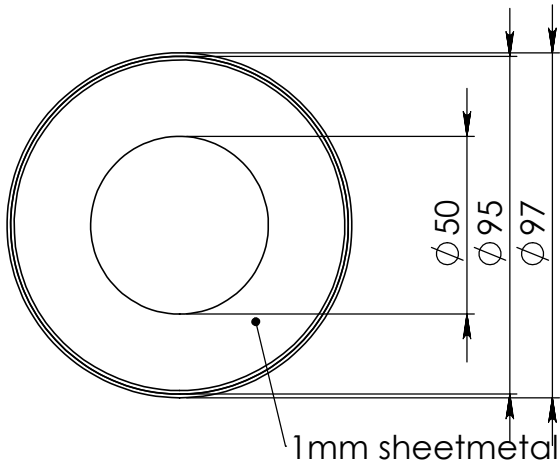

E

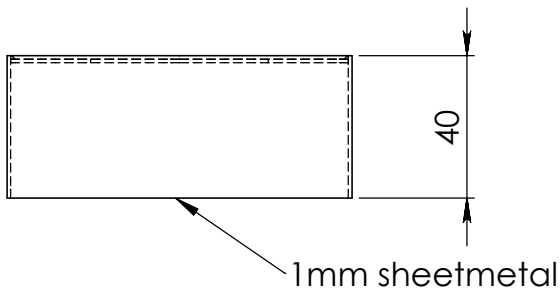

Scale: 1:2

3

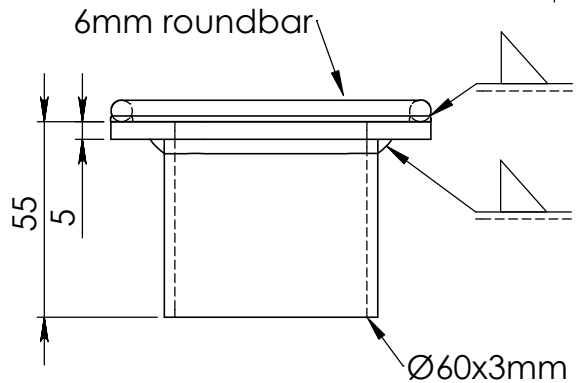
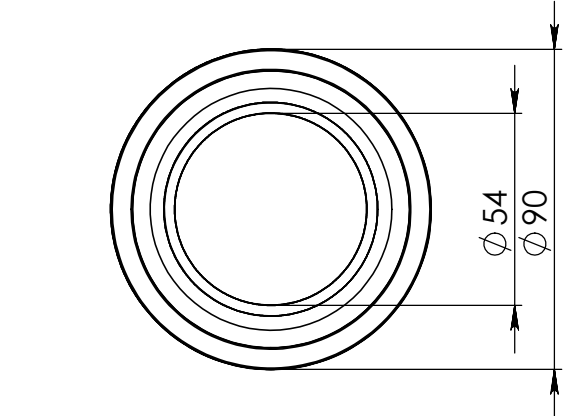

Scale: 1:2

F

01	Swivelpipe Ø50x3x500
02	Bearing cover 1mm
03	Swivel connection

PRACTICA
FOUNDATION

TITLE:

Jetting Swivel (1)

DRAWN BY:
Don de Koning

DATE:
01-06-2010

VERSION:
Final v1.0

DWG NO.

007

SCALE:

1:5

A4

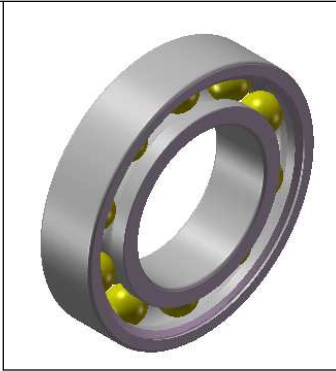
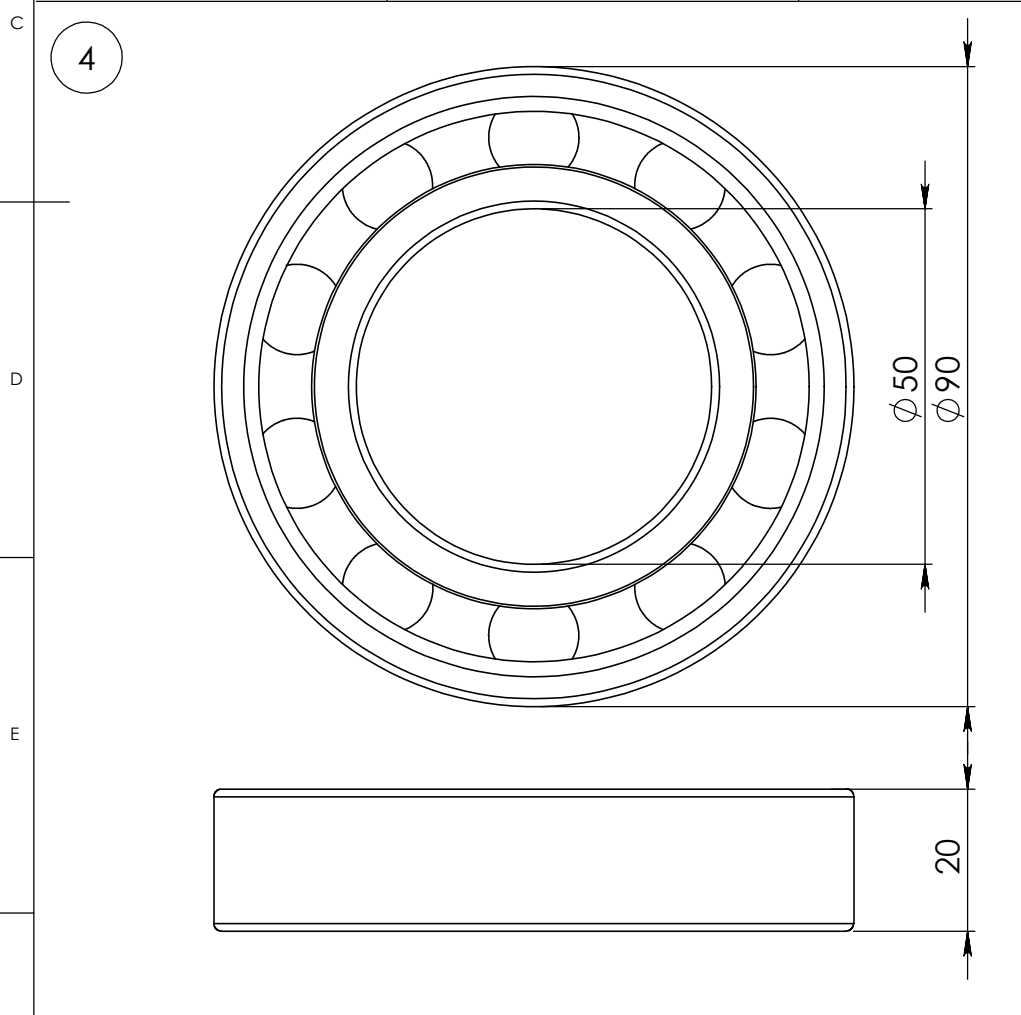
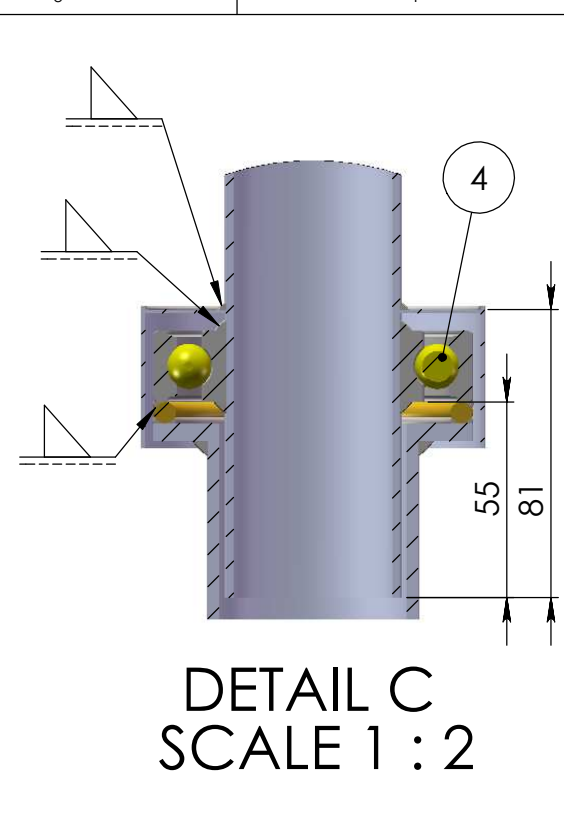
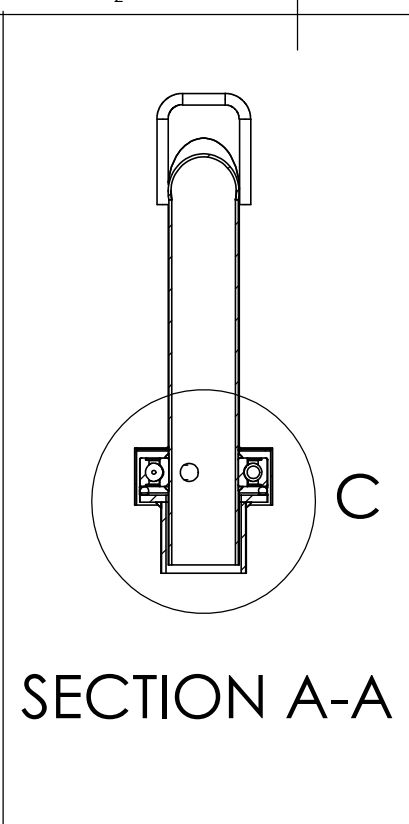
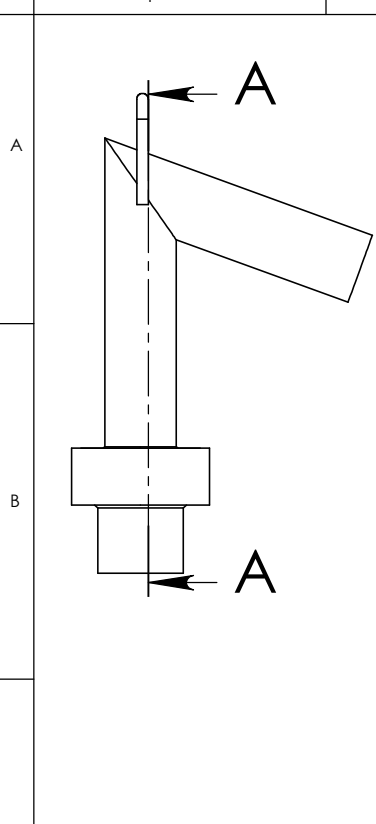

F	04 Bearing SKF 6210			TITLE: Jetting swivel (2)	
				DWG NO. 008	
				SCALE: 1:5	
DRAWN BY: Don de Koning		DATE: 01-06-2010	VERSION: Final v1.0	A4	